



**DESIGN & CONSTRUCTION GUIDELINES**

**DIVISION 23 HEATING, VENTILATING & AIR CONDITIONING (HVAC)**

**DIVISION 23 HEATING, VENTILATING & AIR CONDITONING (HVAC)**

**SECTION 23 00 00 GUIDELINE INTENT ..... 2**

**SECTION 23 05 00 COMMON WORK RESULTS FOR HVAC ..... 6**

**SECTION 23 05 13 COMMON MOTOR REQUIREMENTS..... 10**

**SECTION 23 05 19 METERS AND GAGES FOR HVAC PIPING ..... 13**

**SECTION 23 05 23 GENERAL-DUTY VALVES FOR HVAC PIPING AND EQUIPMENT ..... 15**

**SECTION 23 05 29 HANGERS AND SUPPORT FOR HVAC PIPING AND EQUIPMENT ..... 17**

**SECTION 23 05 48 VIBRATION CONTROLS FOR HVAC PIPING AND EQUIPMENT ..... 19**

**SECTION 23 05 53 IDENTIFICATION FOR HVAC PIPING AND EQUIPEMENT ..... 20**

**SECTION 23 05 93 TESTING, ADJUSTING AND BALANCING (TAB) FOR HVAC ..... 21**

**SECTION 23 07 00 HVAC INSULATION..... 22**

**SECTION 23 08 00 COMMISSIONING OF HVAC..... 25**

**SECTION 23 09 00 INSTRUMENTATION AND CONTROL FOR HVAC ..... 26**

**SECTION 23 21 13 HYDRONIC PIPING..... 34**

**SECTION 23 31 13 HVAC DUCTWORK ..... 36**

**SECTION 23 34 23 HVAC POWER VENTILATORS..... 38**

**SECTION 23 37 13 DIFFUSERS, REGISTERS AND GRILLS..... 39**

**SECTION 23 41 00 PARTICULATE AIR FILTERATION ..... 40**

**SECTION 23 73 13 MODULAR INDOOR CENTRAL STATION AIR HANDLING UNITS..... 41**

---

**SECTION 23 00 00 GUIDELINE INTENT****1.1 GENERAL REQUIREMENTS**

- A. This division serves as a design and construction guideline for the Professional Architect/Engineer (A/E) and Contractors performing mechanical services at the University of South Florida. This guideline is intended to establish the Universities standard of quality and is not a specification. The A/E shall develop the permit and construction documents in accordance with the intent of the guideline and as necessary to comply with the given project scope and/or program.
- B. In some instances, a product is named to represent a minimum acceptable quality standard as a basis for the A/E. The intent is for the A/E to specify/schedule not less than three manufactures/ models based on similar style, appearance & performance characteristics of the named product.
- C. This guideline lists minimum material quality standards. Materials not contained here-in shall be selected by A/E based on application and where code allows.
- D. Substitution requests shall be in writing to the USF-Project Manager (USF-PM). Notification of substitution acceptance will be in writing; otherwise, the substitute is not accepted.
- E. A/E shall provide all ventilation calculations on the drawings submitted as part of the project permit and construction documents. Ventilation airflow calculations and design plans shall be provided by a Florida licensed professional engineer as per Building Code Administration (BCA). All final calculations shall be submitted to the BCA and USF Mechanical Engineer for review and permit. Calculations shall include all engineering assumptions, occupancy classifications, occupancy values, room areas, rate values, etc. as part of the ventilation calculations scheduled on drawings.
- F. Renovation of existing facilities shall require A/E to evaluate the existing associated HVAC systems and controls to determine if the equipment is in good condition and suitable to be reused in the renovation (i.e.; air-handlers, cooling and heating coils, VAV boxes, control valves, airflow and ventilation quantities and quality of the air). At a minimum, the A/E shall visit the project site to inspect the HVAC system to observe the basic condition of the major HVAC system components and control system. The A/E shall evaluate the Pre-Test and Balance report and accompanying site observations identify any scope that may need to be included in the renovation as necessary for proper HVAC system operation. All relevant observations and recommendations shall be reported in writing to the USF Facilities Management (USF-FM) and USF Mechanical Engineer.

**1.2 DESIGN CRITERIA**

- A. Professional Engineer shall provide Contract Documents prepared in accordance with 61G15, Florida Administrative Code.
- B. Requirements of the latest revision of the USF Cost Containment Guide (CCG), Florida Building Code (FBC), FBC Mechanical Code, FBC Energy Conservation Code, FBC Plumbing Code, and FBC Fuel Gas Code must be met.
- C. Appropriate American Society for Testing and Materials (ASTM), American National Standards Institute (ANSI), Underwriters Laboratory (UL), American Society of Mechanical Engineers (ASME) and National Fire Protection association (NFPA) standards must be met and specified for materials.
- D. The A/E is responsible for developing, documenting, and promoting technical discussion of proposed systems early in the project design phase. Early submittals are to include narrative technical discussion of system types, materials, and controls; including options, advantages, disadvantages, relative costs, and architect/engineer recommendations.
- E. USF has invested into very energy efficient central chilled water and hot water systems to serve the campus. As such, the A/E shall utilize the Central Campus Chilled Water and Hot Water Systems as a basis for the project HVAC design. Other system types including direct expansion (DX) are not allowed unless an exception is requested and approved by USF-FM. In order to obtain approval, the request shall be accompanied by a Life Cycle Cost Analysis (LCCA) building energy calculations showing the life cycle cost benefit to USF for the requested

- substitution. Refer to the [Article 3 \(Technical Applications\), USF Professional Services Guideline \(PSG\)](#) for the substitution request and submission requirements.
- F. During the early concept/design phase, the A/E shall establish the project chilled water and hot water load for the project and review these loads with USF-FM in order to determine that the central plant capacities are satisfactory to support the additional loads. If additional plant capacity and/or distribution infrastructure are necessary, they should be included as a basic part of the project scope.
- G. The A/E shall ensure that all major decisions regarding system types, materials, and controls are determined and agreed to by owner/user by the end of design development phase; and documented in the design development submittal. Costs are to be included in the A/E's design development estimate of construction cost.
- H. The A/E shall utilize an approved version of either [Trane Trace](#), [Carrier HAP](#) or other pre-approved whole building [8760 hour](#) simulation software for design modeling and performing [Life Cycle Cost Analysis \(LCCA\)](#) building energy calculations. The economic feasibility analysis shall include all project cost over a [25 year](#) life cycle payback analysis. Saving estimates to include maintenance/operations costs as controls integration is required for feedback and monitoring. All project costs, testing, equipment, controls, etc., and maintenance costs shall be included in the economic feasibility analysis calculations. The LCCA shall be used as a basis for making specific equipment selections including Energy Recovery Equipment where applicable on project. The LCCA shall include: installed equipment cost, maintenance and operating cost as a basic part of the feasibility analysis. The A/E shall provide the completed model in electronic file to the owner at the end of the design phase. Refer to the [USF Professional Services Guide \(PSG\)](#) for additional LCCA requirements.
- I. Engineering Assumptions
1. INDOOR DESIGN CONDITIONS (by season): Temperature, relative humidity. Cooling: [75 °F / 50 % RH](#). Heating: [70 °F](#).
  2. OUTDOOR DESIGN CONDITIONS (by season): Temperature, humidity, wind direction and velocity. Note: Florida may be defined as a humid climate. [See American Society of Heating, Refrigerating and Air-Conditioning Engineers \(ASHRAE\) Fundamentals Handbook](#) (latest year). Cooling: [92 °F DB / 77 % CWB](#). Heating: [36 °F](#).
  3. Cooling coil design selections shall be based on [45 °F](#) coil entering temperatures and [15 °F](#) water temperature rise, producing a nominal leaving air temperature of [52 °F](#) off the coil. Hot water coil design selections shall be based on [160 °F](#) coil entering temperatures and [50 °F](#) water temperature rise, producing a nominal leaving air temperature of minimum [85 °F](#) off the coil. Design pressures for distribution shall be [200 psi](#). A/E shall notify USF-FM if the project conditions require any deviations from these values.
  4. Condenser water design pressures shall be determined by the A/E.
  5. A/E shall model the HVAC system based on anticipated occupancy values for the given occupancy classification and activities performed for each type of space in the building.
  7. A/E shall model the HVAC system based on actual electrical load for lighting and miscellaneous equipment anticipated to be used in occupied spaces.
  8. A/E shall model the HVAC system based out of the ordinary or special thermal and moisture loads anticipated to be used in occupied spaces.
  9. Minimum outdoor air volume shall be calculated as required by [FBC-Mechanical Ventilation](#) or provide an [ASHRAE 62](#) (latest edition) Alternative with appropriate Addenda.
    - a. The [Ventilation Rate Procedure \(VRP\)](#) as described in [FBC-Mechanical](#) is a prescriptive procedure in which outdoor intake rates are determined based on space type application, occupancy level and floor area.
    - b. The alternate method in [ASHRAE 62](#) is the Indoor Air Quality method in which outdoor intake rates and other system design parameters are based on an analysis of contaminant sources, contaminant concentration targets and perceived acceptability targets. This method is not recommended for most applications on campus.
    - c. Class of air assumptions for exhaust and recirculation air streams.
- J. The overall building envelope shall be positively pressurized relative to the outdoor air pressure. The HVAC design goal shall maintain a proper balance of entering and exhausting

- air-streams in order to maintain an indoor building pressure at or above 0.02 inches of water column.
- K. Variable Air Volume (VAV) System designs should include demand-control ventilation (DCV) and shall have sufficient sensor coverage in the air-conditioned zones and large rooms for Indoor Air Quality (IAQ) to implement this strategy and as required for compliance with the FBC–Energy Conservation. The control system shall maintain the system ventilation flowrate as necessary to satisfy the proper IAQ. The VAV air-handlers shall include outside air volume dampers and Return control dampers of the quality as referenced in Section 23 09 00 Instrumentation and Control for HVAC.
- J. Laboratory HVAC
1. Building spaces with fume hoods and animal holding facilities typically are prohibited by code and good practice from recirculation of air conditioning air: 100% outside air is required. Clean room "class" per ASHRAE must be determined and documented. Since 100% outside air systems and other special systems are expensive to build, operate and maintain, and since the size and complexity of the systems create ample opportunity for design, contract, construction, initial start-up and noise problems, it is critical that the detailed design basis and costs be established and documented in early design submittals.
  2. All 100% outside air units shall be equipped with preheat coils.
  3. The A/E shall design exhaust systems as necessary to meet or exceed the code requirements for laboratory spaces in accordance with NFPA 45.
  4. Air exhausted from chemical fume hoods and other special local exhaust systems shall not be recirculated.
  5. Energy conservation devices that could result in recirculation of exhaust air or exhausted contaminants shall not be used unless designed in accordance with American National Standards Institute / American International Health Alliance (ANSI/AIHA) Z9.5, "Nonlaboratory Air", or "General Room Exhaust," Laboratory Ventilation.
  6. Air exhausted from laboratory work areas shall not pass unducted through other areas.
  7. Air from laboratory units and laboratory work areas in which chemicals are present shall be continuously discharged through duct systems maintained at a negative pressure relative to the pressure of normally occupied areas of the building.
  8. Positive pressure portions of the lab hood exhaust systems (e.g., fans, coils, flexible connections, and ductwork) located within the laboratory building shall be sealed airtight or located in a continuously mechanically ventilated room.
  9. Chemical fume hood face velocities and exhaust volumes shall be sufficient to contain contaminants generated within the hood and exhaust them outside of the laboratory building.
  10. The hood shall provide containment of the possible hazards and protection for personnel at all times when chemicals are present in the hood.
  11. Special local exhaust systems, such as snorkels or "elephant trunks," shall have sufficient capture velocities to entrain the chemical being released.
  12. Canopy hoods shall not be used in lieu of chemical fume hoods.
  13. Only Class II, Type B2 biological safety cabinets listed by National Sanitation Foundation as meeting National Sanitation Foundation / American National Standards Institute (NSF/ANSI) 49, Class II (Laminar Flow) Biosafety Cabinetry, shall be permitted to be used in lieu of chemical fume hoods, as determined by a qualified person.
  14. Laminar flow cabinets shall not be used in lieu of chemical fume hoods.
  15. Air exhausted from chemical fume hoods and special exhaust systems shall be discharged above the roof at a location, height, and velocity sufficient to prevent re-entry of chemicals and to prevent exposures to personnel.
  16. Fume Hoods shall be variable position sash type. Two position sash fume hoods are not acceptable. A/E shall review fume hood selections, safeties and control integration features with USF Mechanical Engineers prior to finalizing design concepts.
- K. Janitor Closets
1. Designated use areas including housekeeping, custodial rooms, laundry areas, etc. shall comply with the following requirements:

- a. Provide minimum exhaust rate of 1.0 cfm/sf and stated pressure differential, with no air recirculation. The pressure differential with the surrounding spaces must be at least 0.02 inches of water gauge on average and 0.004 inches of water at a minimum when the doors to the rooms are closed.
- b. Self-closing doors on all spaces outlined above.
- c. Deck-to-deck partitions or hard-lid ceilings. Joints shall be sealed.

### 1.3 DRAWING REQUIREMENTS

- A. Plans, sections, and isometric drawings shall be prepared for the required HVAC systems.
- B. Drawings shall detail mechanical rooms and include section cuts in all directions as necessary to convey clearly all pipe elevations, crossings and the equipment connections/locations. Mechanical room minimum scale shall be 1/4 inch = 1 foot - 0 inch Drawings shall show location of pipes, electrical equipment, drains, hose bib, etc. All equipment service clearances shall be dimensioned. Detail air handlers including adequate number of sections, and coil and filter removal clearances, and access (including size) for coil cleaning, etc. Provision shall be made for shaft removal.
- C. Drawings shall include detailed equipment layouts and shall show dimensions: equipment, clearance spaces, inertia bases, housekeeping pads, drains, invert level for all piping, detail of pipe welds, etc.
- D. Drawings shall include flow diagrams, system descriptions and a piping and instrumentation diagrams detailing all piping, equipment, instruments, instrument loops, control interlocks Interface for class/material change, annunciation inputs, control relays, manual switches, indicating lights, etc.
- E. The flow diagrams shall show all equipment, names, and equipment tag names, all valves, all instruments/controls, pipeline identification, valve identification, all line size transitions, direction of flow, interface for class/material change, annunciation inputs, control relays, manual switches, indicating lights, etc.
- F. System description shall include basis of design, operating modes (start-up, normal, shut down, emergency, etc.), description and performance ratings of major equipment, control concepts and control sequence.
- G. Flow diagrams shall include all major equipment, capacities or ratings, names and identification number, bypass and recirculation lines, control valves, valves required for routing for all modes, pipe sizes, and connection to other systems.
- H. Drawings shall include detailed pipe support drawings. Pipe support drawings shall include all dimensions, materials, fabrication procedures, fastening methods, pipe saddles, etc.
- I. Drawings shall include detailed equipment connections and shall show all pipe/sizes dielectric unions or flanges, line-size transitions, vibration isolators, strainers, isolating valves, control valves, and instruments including gage cocks, air vents including isolating valves; drains including isolating valves, etc.
- J. Drawings shall include detailed equipment layouts and shall show dimensions for equipment, clearance spaces inertia bases, housekeeping pads, Drawing shall also include location of drains, invert level (bottom or top of pipe) for all piping shown on drawings. Detail of pipe welds shall be shown on drawings.
- K. Drawings shall indicate pipe size vs. insulation thickness. Detail of pipe insulation shall include K-Value, method of installation, vapor barrier details, insulation shield detail (where required).

---

END OF SECTION 23 00 00

---

**SECTION 23 05 00 COMMON WORK RESULTS FOR HVAC****PART 1 – GENERAL****1.1 PERMITS AND INSPECTIONS**

- A. Follow USF Building Code Administration (BCA) requirements for permitting and scheduling inspections. Coordinate with USF BCA department.
- B. Minor Projects: Contractor is responsible for all permitting and inspecting fees.
- C. Major Projects: Coordinate with USF-PM for responsible party for permitting fees.
- D. Minor Projects with USF approved Construction Manager (CM): Coordinate with USF-PM and assigned CM for responsible party for permitting fees.
- E. Obtain and adhere to the Universities Hot Work Permit for each instance in accordance with the BCA requirements.

**1.2 COORDINATION**

- A. Visit the site included in the scope of work to ascertain existing conditions. Verify all dimensions and locations before proceeding with work in the area and prior to purchasing equipment.
- B. Review and coordinate between all construction documents, all project specifications, and all sections in USF Design and Construction Guidelines (DCG). Notify USF-PM of conflicts or discrepancies prior to proceeding with work.
- C. Locate all underground utilities required by the Sunshine Law prior to proceeding with work. Contact USF-PM to obtain latest USF Campus Utilities Map for the area in scope of work prior to proceeding.
- D. Coordinate with USF-PM, USF Parking and Transportation Services (USF-PTS), and USF Police Department (USF-UPD) for required lane closures and parking spaces closures minimum 72 hours prior to closures. Contractor is responsible for all closure barriers and signs subject to USF review and approval.
- E. Isolation of Existing Utilities: Contract drawings shall include general notes requiring Contractor to coordinate and schedule any and all work impacting existing facilities with the USF PM at a minimum of 2 weeks prior to the anticipated work. Utility isolation valves located in manholes on site or in existing buildings shall only be exercised by USF Facilities Management-Operations (FM-OPS) personnel. In many instances, underground isolation valves have not been able to close-off bubble tight. The contract documents shall include a contingency plan to test the valves prior to cutting into the system. If the valves do not hold adequately to allow Contractor to perform the tie-in, the USF PM shall be notified immediately.

**1.3 SUBMITTALS**

- A. Submit one electronic copy of HVAC Submittals as a single bookmarked pdf. Include a table of contents, bookmark/tab manual based on specification chapters or sections.

**1.4 SITE**

- A. All existing utilities shall remain in place unless otherwise noted on the contract documents.
- B. Contractor shall restore back to original installation primary gear, primary feeders, utilities, irrigation, etc. damaged by the contractor in the area of demolition or construction.
- C. Provide an erosion control plan addressing prevention, control, and abatement of water pollution to USF-PM for approval prior to proceeding with work.
- D. Safety fencing shall be neon green. Orange or black safety fencing shall not be used.
- E. Conduit trenches shall be backfilled completely to provide safe crossing by the end of workday or whenever the work zone becomes inactive.
- F. Maintain access to side streets, drives, and sidewalks at all times during construction.
- G. Existing pedestrian/sidewalk lighting and roadway lighting shall remain operational during all phases of the construction until new lighting is energized.
- H. Construction Sites: Provide protective barriers around open HVAC trenches manholes. USF shall have clear vehicle access to these items at all times during construction.
- I. HVAC manholes: Provide 10 feet square barricade around manhole cover. Manhole cover shall be accessible to USF at all times. Remove construction debris such as dirt, sod, ground cover, etc.

- J. Temporary services protective barricades shall allow 3 feet clearance on sides and rear (or required by code if greater), and 5 feet clearance in front of equipment.
- K. No construction materials or construction tools shall be stored within the protective barricades.
- L. No construction vehicles or personal vehicles shall be parked over manhole covers.
- M. Project site design and final site constructed conditions shall include clear vehicle access to all above mentioned equipment for maintenance.
- N. Fenced Construction Sites: An access point agreed to by USF-PM and FM-OPS department shall be provided to USF. Chains shall have USF Standard 2000 Padlock and site contractor pad lock daisy chained. Project is responsible to provide the USF Standard 2000 Padlock, coordinate with USF-PM and FM-OPS department.
- O. Areas where work is performed shall be kept clean of debris and materials and shall be cleaned at the end of each work day. Contractor is responsible to secure all tools and materials at all times.
- P. Remove existing equipment and materials, etc, identified to be removed on plans. Equipment removed should be offer to USF to be kept as spares. If USF elects to not keep equipment as spare, the Contractor shall remove and dispose of properly. Equipment disconnected or abandoned shall be removed by the Contractor and disposed of properly.
- Q. Provide Tree protection for any tree that may be located within the project construction site or near the lay-down or designated contractor parking area. Parking and Lay-down areas shall be located outside the drip edge of trees. If the project scope impacts within the drip edge of trees in the construction site, the trees shall be properly protected with barriers and/or proper root pruning by qualified arborist. For additional Tree Protection information refer to USF-FM.

#### 1.5 WARRANTY

- A. Contractor shall provide minimum one (1) year warranty for all labor and materials, whether included or not included by equipment manufacturers. Contractor shall replace defective materials during the first year of warranty without additional compensation from USF.
- B. Manufacturer warranties greater than one (1) year, or where lengthier warranties are required in the project documents, or in USF Design and Construction Guidelines (DCG) shall extend the standard one (1) year warranty.
- C. Warranty period shall begin on date of substantial completion.

#### 1.6 MISCELLANEOUS

- A. USF Furnished Equipment:
  - 1. Contractor shall be responsible for receipt from USF, storage after receipt, and installation if required.
  - 2. Verify equipment connection requirements prior to rough-in and ordering materials.
  - 3. Install equipment in accordance with manufacturer instructions.
  - 4. Maintain equipment until project is turned over to USF at Substantial Completion.
- B. A/E for new construction and renovations or contractor for miscellaneous additions shall demonstrate that the existing services have the required additional capacity and can accommodate the load being added.
- C. A/E for new construction and renovations or contractor for miscellaneous additions shall demonstrate that the existing services are at adequate depth to accommodate the minimum slope requirements for tie-in of new to existing services.

#### 1.7 PROJECT CLOSE OUT

- A. Submit one electronic copy and one hard copy of Operations Manual as a single bookmarked pdf. Include a table of contents, bookmark/tab manual based on specification chapters or sections.
- B. Provide record documents per USF-FM requirements. Coordinate with USF-PM. Record documents shall include updated as-built drawings. Submit working CAD drawings (with bound Xref files) on disk or other approved memory storage device include separate folder or disk including pdf copies of each as-built drawing. Filenames shall include drawing number as reference.

**PART 2 – PRODUCTS (Not Used)**

**PART 3 – EXECUTION**

**3.1 FIELD QUALITY CONTROL**

- A. Existing Utilities (CW, HW, Potable Water, Electrical, Communications, etc.): The A/E shall survey the existing site conditions and review current utility plans with USF-FM to evaluate needs for the project and locations below grade to avoid conflicts.
- B. Do not operate air handling units (AHU's) during building construction phases unless filtration media with a Minimum Efficiency Reporting Value (MERV) of 8 are used at each return air grill, as determined by ASHRAE 52 to protect ductwork during construction.
- C. Seal all return air openings with plastic and close all return air dampers during construction. Protect fan motors, switches, equipment, fixtures and other items from dirt, rubbish and foreign matter. Do not operate AHU's if the building construction operations such as sanding drywall or any operations that may potentially contaminate the mechanical systems. Do not operate AHU's if the building is not clean or if dust can enter coils or fan housing and ductwork systems. Do not operate AHU's if the building is not positively pressurized. Do not operate exhaust fans if their operation creates a negative building pressurization.
- D. Monitor and maintain all filters, filter media and all related items during construction and replace all filtration media prior to occupancy prior to occupancy with specified filters with a minimum value of a MERV 8. Minimum MERV 13 filters are required to be installed in all air-handlers at Substantial Completion. Refer to [Section 23 41 00, Particulate Air Filtration](#) for additional requirements
- E. The use of sweeping compounds and cleaning products is required during construction clean up on a daily basis and a complete detailed final cleaning will be performed by a qualified subcontractor prior to HVAC final start up and commission to ensure a clean environment prior to the occupancy of the building. This will be required at the completion of each phase and start up prior to building turnover and occupancy.
- F. Source Control: Use of materials such as adhesives, sealants, and paints shall be low VOC type and comply with Leadership in Energy and Environmental Design (LEED) IEQ credit 4.1 and 4.2. Please make note that no material will be allowed onsite without prior approval and all material will be inspected and verified during the course of this project.
- G. Pathway interruption: During construction, isolate areas of work to prevent contamination of clean or occupied spaces. Provide temporary barriers that contain the construction area.
- H. Housekeeping: Keep interiors of duct and pipe systems clean and free from dirt, rubbish and foreign matter. Prevent dust, debris and foreign material from entering the piping and ductwork. Remove temporary labels, stickers, etc. from fixtures and equipment. Do not remove permanent nameplates, equipment model numbers, etc. Remove debris, rubbish, left over materials, tools and equipment from work areas and site. Daily clean-up is required and will be strictly enforced. Final acceptance shall not be approved until site is cleaned.
- I. Scheduling: All construction activities to be coordinated to minimize or eliminate disruptions of operations in occupied portions of the buildings.

**3.2 COLOR CODING OR LABELING AND IDENTIFYING**

- A. The following band colors and letter designations shall be used:

| Description                  | Label Text             | Label Color |
|------------------------------|------------------------|-------------|
| <b>HVAC Piping</b>           |                        |             |
| Condensate                   | Condensate             | Yellow      |
| Chilled Water Supply (CHWS)  | Chilled Water Supply   | Green       |
| Chilled Water Return (CHWR)  | Chilled Water Return   | Green       |
| Condenser Water Supply (CWS) | Condenser Water Supply | Green       |
| Condenser Water Return (CWR) | Condenser Water Return | Green       |
| Hot Water Supply (HWS)       | Hot Water Supply       | Yellow      |
| Hot Water Return (HWR)       | Hot Water Return       | Yellow      |
| High Pressure Steam 125 psi  | High Pressure Steam    | Yellow      |
| Medium Pressure Steam 50 psi | Medium Pressure Steam  | Yellow      |



| <b>Description</b>        | <b>Label Text</b>    | <b>Label Color</b> |
|---------------------------|----------------------|--------------------|
| Low Pressure Steam 15 psi | Low Pressure Steam   | Yellow             |
| <b>Boiler Feed Water</b>  |                      |                    |
| Boiler Condensate         | Boiler Condensate    | Yellow             |
| Boiler Fill Line          | Boiler Fill Line     | Yellow             |
| Boiler Make-up Water      | Boiler Make-up Water | Yellow             |

---

END OF SECTION 23 05 00

---

**SECTION 23 05 13 COMMON MOTOR REQUIREMENTS****PART 1 – GENERAL****1.1 GENERAL REQUIREMENTS**

- A. Coordinate features of motors, installed units, and accessory devices to be compatible with the following:
  - 1. Motor controllers.
  - 2. Torque, speed, and horsepower requirements of the load.
  - 3. Ratings and characteristics of supply circuit and required control sequence.
  - 4. Ambient and environmental conditions of installation location.
- B. Operation and Maintenance Data
  - 1. Include assembly drawings, bearing data including replacement sizes, and lubrication instructions.
- C. Comply with requirements in this Section except when stricter requirements are specified in HVAC equipment schedules or Sections.
- D. Comply with National Electrical Manufacturers Association (NEMA) MG 1 unless otherwise indicated.
- E. Electrical Service: Refer to Section on Motor Control for required electrical characteristics.
- F. Visible Nameplate: Indicating motor horsepower, voltage, phase, cycles, RPM, full load amps, locked rotor amps, frame size, manufacturer's name and model number, Service Factor, Power Factor, efficiency.

**PART 2 – PRODUCTS****2.1 GENERAL MOTOR REQUIREMENTS**

- A. Comply with requirements in this Section except when stricter requirements are specified in plumbing equipment schedules or Sections.
- B. Comply with NEMA MG 1 unless otherwise indicated.
- C. Electrical Service: Refer to Section on Motor Control for required electrical characteristics.
- D. Visible Nameplate: Indicating motor horsepower, voltage, phase, cycles, RPM, full load amps, locked rotor amps, frame size, manufacturer's name and model number, Service Factor, Power Factor, efficiency.
- E. Electrical Connection: Conduit connection boxes, threaded for conduit. For fractional horsepower motors where connection is made directly, provide conduit connection in end frame.

**2.2 MOTOR CHARACTERISTICS**

- A. Duty: Continuous duty at ambient temperature of 40 deg C and at altitude of 3300 feet above sea level.
- B. Capacity and Torque Characteristics: Sufficient to start, accelerate, and operate connected loads at designated speeds, at installed altitude and environment, with indicated operating sequence, and without exceeding nameplate ratings or considering service factor.

**2.3 POLYPHASE MOTORS**

- A. Description: NEMA MG 1, Design B, medium induction motor.
- B. Service Factor: 1.15.
- C. Multispeed Motors: Variable torque.
  - 1. For motors with other than 2:1 speed ratio, separate winding for each speed.
- D. Multispeed Motors: Separate winding for each speed.
- E. Rotor: Random-wound, squirrel cage.
- F. Bearings: Regreasable, shielded, antifriction ball bearings suitable for radial and thrust loading.
- G. Temperature Rise: Match insulation rating.
- H. Insulation: Class F.
- I. Code Letter Designation:
  - 1. Motors 15 hp and Larger: NEMA starting Code F or Code G.
  - 2. Motors Smaller than 15 hp: Manufacturer's standard starting characteristic.
- J. Enclosure Material: Cast iron for motor frame sizes 324T and larger; rolled steel for motor

- frame sizes smaller than 324T.
- K. Starting Torque: Between one and one and one-half times full load torque.
  - L. Starting Current: Six times full load current.
  - M. Power Output, Locked Rotor Torque, Breakdown or Pullout Torque: NEMA Design B characteristics.
  - N. Testing Procedure: In accordance with American National Standards Institute / Institute of Electrical and Electronics Engineers (ANSI/IEEE) 112, Test Method B. Load test motors to determine freedom from electrical or mechanical defects and compliance with performance data.
  - O. Bearings: Grease lubricated anti-friction ball bearings with housings equipped with plugged provision for relubrication, rated for minimum American Bearing Manufacturers Association (AFBMA) 9, L-10 life of 20,000 hours. Calculate bearing load with NEMA minimum V-belt pulley with belt center line at end of NEMA standard shaft extension. Stamp bearing sizes on nameplate.
  - P. Sound Power Levels: To ANSI/NEMA MG 1.
  - Q. Motors for variable speed (PWM) application shall conform to NEMA Standard MG 1 2016, Part 30 and Part 31.
  - R. Nominal Power Factor: Meet or exceed values in Schedules at full load and rated voltage when tested in accordance with ANSI/IEEE 112.

## 2.4 POLYPHASE MOTORS WITH ADDITIONAL REQUIREMENTS

- A. Motors Used with Reduced-Voltage and Multispeed Controllers: Match wiring connection requirements for controller with required motor leads. Provide terminals in motor terminal box, suited to control method.
- B. Motors Used with Variable Frequency Controllers: Ratings, characteristics, and features coordinated with and approved by controller manufacturer.
  - 1. Windings: Copper magnet wire with moisture-resistant insulation varnish, designed and tested to resist transient spikes, high frequencies, and short time rise pulses produced by pulse-width modulated inverters.
  - 2. Energy- and Premium-Efficient Motors: Class B temperature rise; Class F insulation.
  - 3. Inverter-Duty Motors: Class F temperature rise; Class H insulation.
  - 4. Thermal Protection: Comply with NEMA MG 1 requirements for thermally protected motors.

## 2.5 SINGLE-PHASE MOTORS

- A. Motors larger than 1/20 hp shall be one of the following, to suit starting torque and requirements of specific motor application:
  - 1. Permanent-split capacitor.
    - a. Starting Torque: Less than 150 percent of full load torque.
    - b. Starting Current: Up to seven times full load current.
    - c. Breakdown Torque: Approximately 200 percent of full load torque.
    - d. Drip-proof Enclosure: Class A (50 degrees C temperature rise) insulation, NEMA Service Factor, prefabricated sleeve or ball bearings.
    - e. Enclosed Motors: Class A (50 degrees C temperature rise) insulation, 1.0 Service Factor, prelubricated ball bearings.
  - 2. Split phase.
    - a. Starting Torque: Exceeding one fourth of full load torque.
    - b. Starting Current: Up to six times full load current.
    - c. Multiple Speed: Through tapped windings.
    - d. Open Drip-proof or Enclosed Air Over Enclosure: Class A (50 degrees C temperature rise) insulation, minimum 1.0 Service Factor, prelubricated sleeve or ball bearings, automatic reset overload protector.
  - 3. Capacitor start, inductor run / Capacitor start, capacitor run.
    - a. Starting Torque: Three times full load torque.
    - b. Starting Current: Less than five times full load current.
    - c. Pull-up Torque: Up to 350 percent of full load torque.

- d. Breakdown Torque: Approximately 250 percent of full load torque.
- e. Motors: Capacitor in series with starting winding; capacitor-start/capacitor-run motors shall have two capacitors in parallel with run capacitor remaining in circuit at operating speeds.
- f. Drip-proof Enclosure: Class A (50 degrees C temperature rise) insulation, NEMA Service Factor, prelubricated sleeve ball bearings.
- g. Enclosed Motors: Class A (50 degrees C temperature rise) insulation, 1.0 Service Factor, prelubricated ball bearings.
- B. Multispeed Motors: Variable-torque, permanent-split-capacitor type.
- C. Motors 1/20 hp and Smaller: Shaded-pole type.
- D. Thermal Protection: Internal protection to automatically open power supply circuit to motor when winding temperature exceeds a safe value calibrated to temperature rating of motor insulation. Thermal-protection device shall automatically reset when motor temperature returns to normal range.

## **2.6 EFFICIENCY**

- A. All motors shall be NEMA Premium Efficient Electric Motors according to the latest Energy Independence and Security Act.

## **PART 3 – EXECUTION**

### **3.1 EXECUTION**

- A. After Test and Balance (TAB), full load amps/voltage shall be tagged on all air handlers and pumps motors and fan motors over 1 hp.

---

END OF SECTION 23 05 13

---

**SECTION 23 05 19 METERS AND GAGES FOR HVAC PIPING****PART 1 – GENERAL****1.1 GENERAL REQUIREMENTS**

- A. Drawings shall show location of all gages and meters. Detail of installation shall be shown on drawing. Detail shall include all valves, nipples, unions, thermometers, wells, material of construction, range of gages/meters, etc. All meter locations should be easily serviceable and not in the way of other maintenance needs of other equipment.

**1.2 MATERIALS**

- A. The following meters (where applicable) shall be required on all projects, including garages.
  - 1. Chilled and Hot Water
  - 2. Electric: Refer to [Section 26 27 13](#) for Primary Electrical Metering requirements. Refer to [Section 23 05 19 Part 2, Products](#), for Secondary or sub-meter Electrical Metering requirements.
  - 3. Domestic Water
- B. PRESSURE shall be read by a differential pressure (DP) gage, calibrated in “feet.” (DP gage has two inputs, one high pressure and one low pressure.)
- C. PRESSURE GAGES shall be selected so that failure will relieve pressure to the rear of gage.
- D. GAGES/METERS shall be selected to operate midway of their scale.

**PART 2 – PRODUCTS****2.1 CHILLED WATER & HOT WATER METERING**

- A. [Onicon System 10 BTU Meter](#) and [Onicon Electromagnetic Flow Meters 1-1/4 inch](#) pipe size and larger shall be [F-3500](#) Insertion type unless otherwise noted on the reference USF website. For pipe sizes smaller than [1-1/4 inch](#), Electromagnetic Flow Meters shall be [F-3100](#) In-line type unless otherwise noted on the reference USF website.
- B. BTU meters shall be installed in mechanical rooms in accessible locations. Coordinate data cabling with USF. Flow meters shall be installed on the pipe that meets manufacturer’s installation requirement.
- C. BTU meters shall have [BACnet MS/TP](#) communication capability.

**2.2 EQUIPMENT FOR ELECTRICITY METERING OF USF PROVIDED PRIMARY**

- A. Electric – [Veris E50H2](#) or equivalent pre-approved electric meter for panel installation. [Measurlogic DTS SKT](#) series or equivalent pre-approved electric meter for socket installation.
- B. Electric meters shall have [BACnet MS/TP](#) communication capability. Data available for monitoring via [BACnet](#) communication shall include following:
  - 1. Display: LCD with characters not less than [0.25 inches](#) high.
  - 2. Monitoring: A, V, VA, kW, kvar, kWh, kvarh, kVAh, PF, Hz.
  - 3. Demand metering: W, var, A, VA
- C. A disconnect switch or breaker shall be provided on the line side to isolate the meter from the supply for maintenance. Isolating means via circuit breaker shall be provided for panel mount installation to allow maintenance of meter without de-energizing the switchboard service.

**2.3 DOMESTIC WATER METERING**

- A. [Neptune MACH 10](#) Ultrasonic Meter for pipe sizes up to [2”](#). [Neptune TRU/FLO](#) Compound Meter for pipe sizes above [2”](#).
- B. [Neptune Cellular Meter Interface Unit \(CMIU\)](#) shall be provided for automated meter reading (AMI). USF Utilities shall integrate the meter CMIU to USF account/system.

**PART 3 – EXECUTION****3.1 EXECUTION**

- A. ALL GAGES/METERS shall be installed such that they can be read easily, i.e., grouped together and facing in the same direction.
- B. METERS for measuring potable, chilled, and hot water BTU meters and gas shall be installed before the first point of use in buildings.

- C. BTU meters and BACnet router/controller panels shall be located in mechanical rooms at normal panel height with appropriate access clearances.
- D. Install meters with appropriate distance from change in pipe direction and install with manufacturers recommended upstream and downstream straight length equivalents.
- E. All wiring shall conform to the requirements specified under [Division 23 09 00, Instrumentation and Control for HVAC](#) and [Division 26, Electrical](#).

**3.2 INTEGRATION**

- A. Utilities Control System is a dedicated BACnet DDC control system separate from Building HVAC Control System. All meters and DDC controllers utilized to interface with meters for utilities services shall be tied into Utilities Control System. If there is no BACnet DDC control system available then a BACnet MS/TP to BACnet/IP communication router shall be provided. Router shall be plugged in to the network port provided by USF Information Technology.
- B. All meters and DDC controllers utilized to interface with meters for building HVAC shall be tied into existing Building HVAC Control System. If there is no BACnet DDC control system available then a BACnet MS/TP to BACnet/IP communication router shall be provided. Router shall be plugged in to the network port/data jack provided and installed by USF Information Technology.
- C. Refer to the diagram below for a typical installation/integration or contact the USF Facilities Management Utilities Department. Any exception shall require pre-approval.

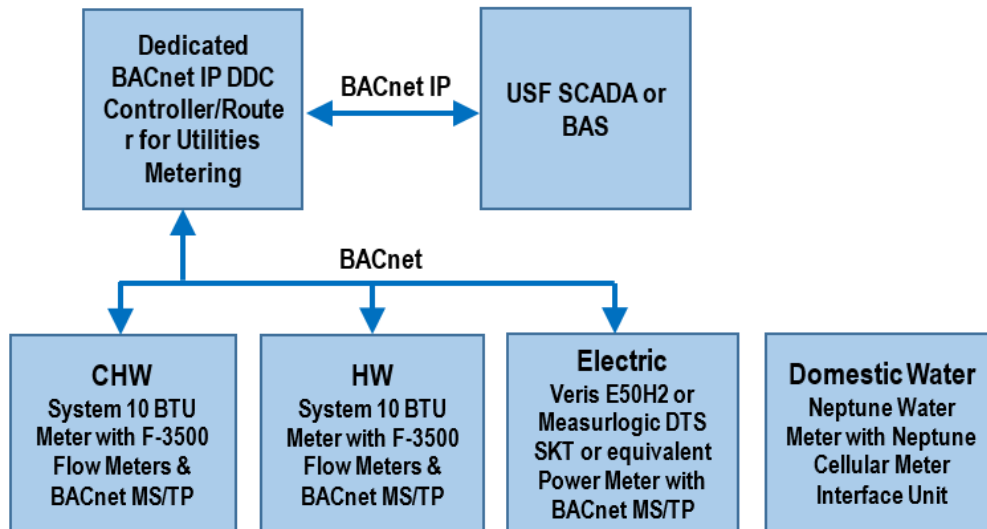

END OF SECTION 23 05 19

---

**SECTION 23 05 23 GENERAL-DUTY VALVES FOR HVAC PIPING AND EQUIPMENT****PART 1 – GENERAL****1.1 GENERAL REQUIREMENTS FOR VALVES**

- A. Source Limitations for Valves: Obtain each type of valve from single source from single manufacturer.
- B. All valves are to be rated at working Pressure of 200 psig, 250 °F minimum WOG, or greater if engineering design demands. Stems are to point vertically or horizontally and must be located for easy service or repair. A valve schedule showing details; number, size, type, material, etc. of all valves should be shown on the Drawings.
- C. Provide Valve Pressure and Temperature Ratings not less than indicated and as required for system pressures and temperatures.

**PART 2 – PRODUCTS****2.1 MATERIALS**

- A. Check valves are to be Y-Pattern 200 psi, WOG, swing check. For 2 inches and smaller are to be bronze body, integral seat with renewable bronze disc. Sizes larger than 2 inches shall include bronze disc, stainless steel spring, and cast iron body.
- B. Balancing Valves - For 2 inches and smaller, use screwed bronze with Pointer and calibrated readout plate and machined orifice. For sizes larger than 2 inches, specify flow meter with machined orifice and two (2) readout connections. Provide a valve with locks located five (5) pipe diameters up-stream of the orifice.
- C. Valves in Insulated Piping shall include stem extensions to account for installed insulation thickness sufficient to allow full stem movement/rotation.
- D. Install valves with unions or flanges at each piece of equipment arranged to allow service, maintenance, and equipment removal without system shutdown.
- E. Provide the following above ground Valve Actuator Types:
  1. Gear Actuator: For quarter-turn valves NPS 8 and larger.
  2. Handwheel: For valves other than quarter-turn types.
  3. Handlever: For quarter-turn valves NPS 6 and smaller [except plug valves].
  4. Chainwheel: Device for attachment to valve handwheel, stem, or other actuator; of size and with chain for mounting height, as indicated in the "Valve Installation" Article.
- F. Valves in Insulated above ground piping: With 2 inch stem extensions and the following features:
  1. Ball Valves: Full port with extended operating handle of non-thermal-conductive material, and protective sleeve that allows operation of valve without breaking the vapor seal or disturbing insulation.
  2. Butterfly Valves: With extended neck.
- G. Provide the following above ground Valve-End Connections:
  1. Flanged: With flanges according to ASME B16.1 for iron valves.
  2. Threaded: With threads according to ASME B1.20.1.
- H. Install valves with unions or flanges at each piece of equipment arranged to allow service, maintenance, and equipment removal without system shutdown.
- I. Above ground Application: If valve applications are not indicated, use the following:
  1. Shutoff Service: Full port ball or butterfly valves.
  2. Butterfly Valve Dead-End Service: Single-flange (lug) type.
  3. Throttling Control Valve Service: Belimo Pressure Independent Control Valves. Refer to [Section 23 09 00, Instrumentation and Control for HVAC](#) for more information.
  4. Balancing Service: Globe style calibrated balancing valves with memory stop.
- J. Above ground End connections:
  1. For Copper Tubing, NPS 2 and Smaller: Threaded ends.
  2. For Copper Tubing, NPS 2-1/2 to NPS 4: Flanged ends except where threaded valve-end option is indicated in valve schedules below.
  3. For Steel Piping, NPS 2 and Smaller: Threaded ends.
  4. For Steel Piping, NPS 2-1/2 and Larger: Flanged ends.

- K. Below Ground Shutoff Service: Valves - Provide flanged 2 piece full port epoxy coated cast iron body, stainless steel ball and stem, water, oil, gas, full close-off, 200 psi ball valves. Valves below ground shall be installed in concrete valve box with corrosion resistant hinged access lid properly designed for the traffic condition. Floor of valve box shall not exceed 4 feet deep. If piping to enter valve box is below 4 feet, piping elevation shall transition into and out of valve box with 45 degree fittings. Each valve shall be installed in valve box with orientation and position so handwheel is accessible from surface access opening via to allow for periodic exercising of valves.

### **PART 3 – EXECUTION**

#### **3.1 EXECUTION**

- A. Locate valves for easy access and provide separate support where necessary.
- B. Install valves in horizontal piping with stem at or above center of pipe.
- C. Install valves in position to allow full stem movement.
- D. Install chainwheels on operators for ball, butterfly, gate, globe, and plug valves NPS 4 and larger and more than 96 inches above floor. Extend chains to 60 inches above finished floor.
- E. Provide non-conducting dielectric connections wherever jointing dissimilar metals.
- F. Install unions downstream of valves and at equipment or apparatus connections.

---

END OF SECTION 23 05 23



---

**SECTION 23 05 29 HANGERS AND SUPPORT FOR HVAC PIPING AND EQUIPMENT****PART 1 – GENERAL****1.1 PERFORMANCE REQUIREMENTS**

- A. Detail of all hangers/supports/anchors for equipment, piping, ductwork, etc. shall be shown on drawings. Detail shall include size(s) and material of hangers/supports, fastening details, anchoring details etc. Spacing of hangers/supports shall be shown on drawings.
- B. Pipe work supports/hangers shall be designed as per the latest edition MSS-58 and MSS-69. (MSS - Manufacturers Standardization Society)
- C. Ductwork supports/hangers shall be designed as per the latest edition of SMACNA - HVAC Duct Construction Standard.
- D. Design hangers without disengagement of supported pipe.
- E. General Locations: Steel pipe hangers, miscellaneous steel supports, hardware, bolts, washers, nuts, screws, etc., shall be hot dipped galvanized with a minimum of 1.50 oz/ft on all sides and all field cuts shall be zinc coated.
- F. Located in Harsh and/or Corrosive Environments: Pipe hangers, equipment supports, miscellaneous structure components, hardware, bolts, washers, nuts, screws, etc., shall be non-metallic polyester resin, vinyl ester resin, fiberglass, glass reinforced polyurethane or 316 stainless steel.
- G. Use nonmetallic coatings on attachments for electrolytic protection where attachments are in direct contact with copper tubing.
- H. Provide an adequate and complete pipe support system using approved hangers and supports complete with necessary attachments, shields, inserts, bolts, rods, nuts, washers, and other accessories. Shields shall be a minimum of 12 inches long and of sufficient strength to ensure pipe hangers do not cut into or compromise the insulation integrity.
- I. Provide adequate and complete pipe support system using hangers and supports to allow controlled thermal movement of piping systems, to permit freedom of movement between pipe anchors, and to facilitate action of expansion joints, expansion loops, expansion bends, and similar units. Provide thermal expansion calculations for each system and component subject to stresses

**PART 2 – PRODUCTS****2.1 MATERIALS**

- A. Unless otherwise indicated, factory fabricated hangers, supports, clamps, saddles, shields, and attachments shall comply with MSS requirements for the type or size installation, and comply with manufacturer's published product information. Hangers, supports and anchors shall be sized properly to include insulation.
- B. Hangers shall be isolated from piping to prevent contact with dissimilar metals.
- C. Whenever mechanical equipment rooms are located within or immediately adjacent to the occupied building, vibration dampening hangers and supports shall be specified.

**PART 3 – EXECUTION****3.1 EXECUTION**

- A. HANGERS/SUPPORTS shall be installed true vertical or horizontal.
- B. Installation of hangers, supports, anchors, etc., shall be accomplished after required building structural work is completed. Where piping or equipment is to be suspended from concrete construction, approved concrete inserts shall be set in form work to receive hangers. Hangers suspended from metal or other roof deck are not permitted. Explosive driven fasteners and drilled concrete insets are not permissible.
- C. Spacing attachments, supports, hangers, etc., are to be installed in accordance with MSS-69. Add additional attachments and supports where required for concentrated loads including changes in direction, fittings, and joints.
- D. Piping shall be supported so that no piping weight (live or dead) load is transmitted to pump, equipment, chiller or to other equipment connections. Hangers and supports are to allow controlled movement of piping and to permit freedom of movement between anchors.

- E. Vertical piping shall be anchored to building with two point bearing. Pipe covering and insulation protection shields/saddles shall to be used on all insulated piping.

---

END OF SECTION 23 05 29

---

**SECTION 23 05 48 VIBRATION CONTROLS FOR HVAC PIPING AND EQUIPMENT****PART 1 -- GENERAL****1.1 PERFORMANCE REQUIREMENT**

- A. Contract drawings shall list each piece of equipment/machinery minimum static deflection.
- B. Contract drawings shall list the type of isolator to be used for each piece of equipment/machinery.
- C. Design noise level for each space shall be listed in the drawings and/or specifications.
- D. Whenever mechanical equipment rooms are located within or immediately adjacent to the occupied building, vibration dampening hangers and supports shall be specified.
- E. All motor driven equipment over 2 hp shall be provided with vibration isolation.
- F. All equipment/machinery isolators shall be designed at a minimum natural frequency of six (6) times lower than the driving frequency of the equipment/machinery.
- G. Structures shall have a minimum natural frequency of three (3) times the driving frequency of the supported equipment/machinery.
- H. Inertia base shall be used for all fans operating at 4 inches static pressure. and above or with motors over 40 hp and all base mounted pumps over 15 hp. Engineer shall analyze all rotating equipment and list all which required inertia bases. This list shall be shown on drawings at Advance Schematic phase.
- I. Inertial base shall be sized for a minimum of 1.5 times equipment weight but not less than 6 inches high.
- J. Vibration isolators e.g. flex connections etc. shall be used at all connection points of all vibration generating equipment.
- K. All roof top equipment installation shall be analyzed and roof curb isolation rails specified if necessary. Except for fans, all roof-top equipment shall be approved, in writing, by the University.
- L. A/E shall make recommendation for floating floors where necessary.
- M. Internally isolated fans in air handlers are acceptable when approved by A/E.
- N. SHOP DRAWINGS: Shop drawings shall include as a minimum: Drawing(s) of equipment detailing: operating weight, stiffness of each isolator, mark of each isolator (color coding of each isolator preferred), center of gravity of equipment/machinery, static deflection specified vs static deflection submitted; and static and dynamic load on each isolator.

**PART 2 – PRODUCTS****2.1 MATERIALS**

- A. Springs shall be used for all static deflections greater than 2 inches.
- B. Springs shall be used in conjunction with isolating elastomer.
- C. Inertial bases fill shall be reinforced 3,000 psi concrete.
- D. All isolators outdoors shall be protected. Steel points shall be hot dipped galvanized. Springs and hardware shall be cadmium plated.

**PART 3 – EXECUTION****3.1 EXECUTION**

- A. Install isolators to ensure the integrity of isolators is not compromised, i.e. no short-circuiting exists.
- B. For critical areas, the manufacturer shall inspect isolated equipment and submit report including static deflection.

---

END OF SECTION 23 05 48

---

**SECTION 23 05 53 IDENTIFICATION FOR HVAC PIPING AND EQUIPEMENT****PART 1 – GENERAL****1.1 PERFORMANCE REQUIREMENT**

- A. All Mechanical drawing symbols used shall be in accordance with standards of accepted practice.
- B. All equipment and piping including associated electrical devices, shall be labeled and tagged in accordance with the University's guidelines.
- C. Equipment tags and labels shall be permanently fasten labels on major equipment. Labels shall indicate a list of regular maintenance replacement components (i.e., filters, belts, etc. include quantities and sizes).
- D. Label Content: Include caution and warning information, plus emergency notification instructions.

**PART 2 – PRODUCTS****2.1 MATERIALS**

- A. Labels, tags and signage shall be letter color coded according to service, and background color appropriate for the application and size for ease of readability. Comply with ANSIA13.1.
- B. Labels shall be made of durable long lasting materials able to withstand temperatures up to 160 °F.
- C. Provide Valve Schedules in mechanical rooms to identify valves: For each piping system, on 8-1/2 by 11-inch bond paper. Tabulate valve number, piping system, system abbreviation (as shown on valve tag), location of valve (room or space), normal-operating position (open, closed, or modulating), and variations for identification. Mark valves for emergency shutoff and similar special uses. Copy of the valve-tag schedule shall be included in operation and maintenance data.
- D. Access Panels: Access panels are required in each situation where items requiring maintenance are located above a concealed ceiling. Access panel sizes shall be suitable for application. Access panel locations shall be indicated on contract drawings.

**PART 3 – EXECUTION****3.1 EXECUTION**

- A. Locate tags, signage and equipment labels where accessible and visible.
- B. Install identifying devices before installing acoustical ceilings and similar concealment.
- C. Engraved signs and labels shall be permanently attached with Stainless-steel rivets or self-tapping screws unless approved otherwise.

---

END OF SECTION 23 05 53

---

**SECTION 23 05 93 TESTING, ADJUSTING AND BALANCING (TAB) FOR HVAC****PART 1 – GENERAL****1.1 PERFORMANCE REQUIREMENTS**

- A. TAB Agency shall be NEBB or AABC certified. Submit TAB Plan to A/E for approval. Plan shall include locations of all measuring points, instruments to be used, measurements to be made, method for TAB, etc.
- B. Where a Commissioning Authority is employed, the TAB Plan shall be submitted to this Authority for approval.
- C. The TAB effort shall be as coordinated with the Contractor and performed as scheduled to produce the TAB report which shall be used during the functional performance testing. A copy of the final TAB report should be submitted to the owner and A/E no later than at the time of substantial completion.

**PART 2 – PRODUCTS (Not Used)****PART 3 – EXECUTION****1.2 EXECUTION**

- A. TAB Agency shall verify all controls and perform calibration of flow measuring stations.
- B. TAB results shall be included in the Record Drawings which are included in the Operation and Maintenance Documentation required at Substantial Completion.
- C. TAB shall include building pressurization measurements and summation of the ventilation air, exhaust air, etc. to the building pressurization observations.

---

END OF SECTION 23 05 93

**SECTION 23 07 00 HVAC INSULATION**

**PART 1 – GENERAL**

**1.1 PERFORMANCE REQUIREMENTS**

- A. Design insulation systems for all piping, ductwork and equipment in accordance with the requirements set forth here-in and no less than the minimum per the latest Energy Code requirements. Insulation thickness/K-Value shall be designed to prevent condensation under all operating conditions especially in a hot humid environment.

**1.2 DEFINITIONS**

- A. Hot Surfaces - normal operating temperatures of 100 °F or higher.
- B. Cold Surfaces - normal operating temperatures of 75 °F or less.
- C. Dual Temperature Surfaces - normal operating temperatures that vary from hot to cold.

**1.3 APPLICATIONS**

- A. General: Materials and thicknesses are specified in schedules at the end of this section.
- B. Interior, Exposed Piping Systems and Concealed Piping Systems: Unless otherwise indicated, insulate the following piping systems:
  - 1. Chilled Water.
  - 2. Heating Hot Water.
  - 3. Refrigerant suction lines.
  - 4. Condensate waste piping. Copper condensate pipe on roof does not require insulation.
- C. Exterior, Exposed Piping Systems: Unless otherwise indicated, insulate the following piping systems:
  - 1. Chilled Water.
  - 2. Heating Hot Water.
  - 3. Refrigerant suction lines.
  - 4. Condensate waste piping.

**PART 2 – PRODUCTS**

**2.1 MATERIALS**

- A. Ductwork Insulation (Unless otherwise indicated, insulate the following duct systems)
  - 1. Interior concealed outside air, top of supply air devices, supply and return air Ductwork – Nominally 2.2 inches thick, 0.75 pcf fiberglass wrap and foil scrim kraft jacket with minimum installed insulation value of R-6.
  - 2. Mechanical rooms, interior exposed outside air, supply and return air Ductwork – Nominally 1.5 inch thick, 1.5 pcf fiberglass rigid board and foil scrim kraft jacket with minimum installed insulation value of R-6. Similar to CertaPro Commercial Board, CB150. Insulation requirements for exposed ductwork within interior conditioned spaces shall be evaluated and specified by the A/E.
  - 3. Exterior dual wall outside air, supply and return air Ductwork - : Nominally 1.5 inches thick 1.5 pcf fiberglass rigid liner board securely attached and sandwiched within the solid galvanized interior liner and the aluminum exterior jacket with minimum installed insulation value of R-6.
  - 4. Insulation R-Values/insulation thickness shall be increased to reflect the wider temperature differences to prevent surface condensation and/or heat loss as determined by the A/E.
- B. Schedule of HVAC Duct Insulation. Abbreviations used in the following schedules include: Field-Applied Jackets: P - PVC, K - Foil and Paper, A - Aluminum, SS - Stainless Steel. Pipe Sizes: NPS - Nominal Pipe Size.

| Materials                          | Application   | Thickness (inches) | Vapor Barrier Required | Field Applied Jacket |
|------------------------------------|---|--------------------|------------------------|----------------------|
| <b>Interior Concealed Ductwork</b> |   |                    |                        |                      |
| Duct Wrap                          | Supply & Return; Outside Air; Plenums; Top of Air Devices | 2.2                | Yes                    | None                 |

| Materials  | Application                           | Thickness (inches) | Vapor Barrier Required | Field Applied Jacket |
|--|---------------------------------------|--------------------|------------------------|----------------------|
| <b>Interior Exposed Rectangular Ductwork in Mechanical Rooms</b> |                                       |                    |                        |                      |
| Rigid Board  | Supply & Return; Outside Air; Plenums | 1.5                | Yes                    | None                 |
| <b>Interior Exposed round Ductwork in Mechanical Rooms</b>       |                                       |                    |                        |                      |
| Duct Wrap  | Supply & Return; Outside Air; Plenums | 2.2                | Yes                    | None                 |

- B. Pipe Insulation (Above Ground)
- Cellular Glass Pipe Insulation: Inorganic, incombustible, foamed or cellulated glass with annealed, rigid, hermetically sealed cells similar to Pittsburgh Corning Corporation; Foamglas. Thermal Conductivity: 0.29 BTU-in/hr. ft<sup>2</sup> °F @ 75 °F with maximum flame spread index of 25 and a maximum smoke developed index of 50.
  - Flexible Closed Cell Elastomeric Thermal Preformed Pipe Insulation: Thermal Conductivity: 0.25 BTU-in/hr. ft<sup>2</sup> °F @ 75 °F, thick similar to Armaflex with maximum flame spread index of 25 and a maximum smoke developed index of 50.
  - Glass Fiber Preformed Pipe Insulation with factory applied ASJ similar to Knauf 1000 Pipe Insulation with maximum flame spread index of 25 and a maximum smoke developed index of 50. Thermal Conductivity: 0.23 BTU-in/hr. ft<sup>2</sup> °F @ 75 °F.
- C. Schedule of HVAC Pipe Insulation. Abbreviations used in the following schedules include: Field-Applied Jackets: P - PVC, K - Foil and Paper, A - Aluminum, SS - Stainless Steel. Pipe Sizes: NPS - Nominal Pipe Size.

| Materials   | Pipe Size (NPS) | Thickness (inches) | Vapor Barrier Required | Field Applied Jacket |
|---|-----------------|--------------------|------------------------|----------------------|
| <b>Interior Concealed and Exposed Chilled Water (above 40 degree F)</b>   |                 |                    |                        |                      |
| Cellular Glass  | All             | 2                  | Yes                    | K                    |
| <b>Outdoor Aboveground Chilled Water (above 40 degree F)</b>  |                 |                    |                        |                      |
| Cellular Glass  | All             | 3                  | Yes                    | AL                   |
| <b>Interior Concealed and Exposed Heating Hot Water (200 degree and below)</b>                                  |                 |                    |                        |                      |
| Glass Fiber   | 1/2 to 1-1/4    | 1-1/2              | Yes                    | None                 |
|   | above 1-1/4     | 2                  | Yes                    | None                 |
| <b>Outdoor Aboveground Heating Hot water (200 degree and below)</b>   |                 |                    |                        |                      |
| Cellular Glass  | All             | 2                  | Yes                    | AL                   |
| <b>Interior Refrigerant Suction Lines (add UV protection for outside installation)</b>                          |                 |                    |                        |                      |
| Cellular Glass  | 5/8 to 2-1/8    | 1-1/2              | Yes                    | K                    |
| <b>Exterior Refrigerant Suction Lines (add UV protection for outside installation)</b>                          |                 |                    |                        |                      |
| Flexible Elastomeric  | 5/8 to 2-1/8    | 1                  | No                     | None                 |
| <b>Condensate Waste Piping Within Mechanical Rooms or Outdoors (add UV protection for outside installation)</b> |                 |                    |                        |                      |
| Flexible Elastomeric  | All             | 3/4                | No                     | None                 |

## PART 3 – EXECUTION

### 3.1 GENERAL

- Armaflex shall not be split for installation.
- Insulation shall not be applied until systems are cleaned and satisfactorily tested. All piping and other work to be insulated shall be free of building debris, flux, and foreign material. Duct shall be clean, dry, and free of rust prior to installation of insulation.
- Insulation and vapor barrier shall be continuous through sleeves, walls penetrations, openings and hangers.
- Installation shall be in strict accordance with manufacturer's instructions.
- Flanges, valves, vessels and fittings shall be insulated and finished the same as pipe. Even if the manufacturer's standards for pre-insulated piping allows gaps in the continuity of the insulation, such shall be specified to be made continuous.

- F. Continuous unbroken vapor barrier jackets are required on cold surfaces. Special attention is to be given to prevent condensation and subsequent deterioration of piping.
- G. Insulation shall be protected at supports and hangers. Shields or saddles adequate to support the weight of pipe without crushing the insulation shall be provided.
- H. Foam plastic insulation is not permitted within buildings or in overhangs or within 5 feet of the building perimeter.
- I. Insulation for pumps, heat exchangers, and similar equipment, that may require periodic inspection or maintenance, shall be fabricated in easily removed sections.
- J. Install insulation materials, accessories, and finishes with smooth, straight, and even surfaces; free of voids throughout the length of equipment and piping including fittings, valves, and specialties.
- K. Install accessories compatible with insulation materials and suitable for the service. Install accessories that do not corrode, soften, or otherwise attack insulation or jacket in either wet or dry state.
- L. Keep insulation materials dry during application and finishing.
- M. Install insulation with tight longitudinal seams and end joints. Bond seams and joints with adhesive recommended by insulation material manufacturer.
- N. Install insulation with least number of joints practical.
- O. Install insulation over fittings, valves, strainers, flanges, unions, and other specialties with continuous thermal and vapor-retarder integrity, unless otherwise indicated.
- P. Insulate instrument connections for thermometers, pressure gages, pressure temperature taps, test connections, flow meters, sensors, switches, and transmitters on insulated pipes, vessels, and equipment. Shape insulation at these connections by tapering it to and around the connection with insulating cement and finish with finishing cement, mastic, and flashing sealant.
- Q. Any condensate and/or refrigerant piping (or other cold surfaces) routed above interior ceilings or over interior finished spaces shall be insulated with Cellular Glass insulation. This shall insulation shall include a continuous vapor barrier, etc. (i.e.; Flexible Elastomeric foam insulation is not satisfactory). Flexible Elastomeric foam insulation is satisfactory for condensate pipe insulation within mechanical rooms

---

END OF SECTION 23 07 00



---

**SECTION 23 08 00 COMMISSIONING OF HVAC****PART 1 – GENERAL****1.1 PERFORMANCE REQUIREMENTS**

- A. Functional Performance Testing of the building HVAC and DDC Controls shall be a basic part of the A/E scope of services necessary to verify and validate the proper construction and operation of the systems according to the signed/sealed construction documents and per the Engineer of Records design intent.
- B. A/E shall discuss which level of commissioning is desired by USF prior to entering into contract with USF for professional services. The Commissioning Authority should be selected before award of contracts.
- C. If USF chooses to hire a third party Commissioning Authority for Building Commissioning (including Functional Performance Testing of the building HVAC and DDC Controls), the A/E shall support the commissioning effort to the extent necessary for interpretations of the design intent and to uphold their Engineer of Record responsibilities.
- D. The A/E and Commissioning Authority shall use the latest edition of ASHRAE Guideline as the basis for Building HVAC and DDC Controls Commissioning.

**PART 2 – PRODCUTS (Not Used)****PART 3 – EXECUTION****3.1 EXECUTION**

- A. Once the level of commissioning is determined, the A/E shall develop the specifications incorporating specific language supporting the commissioning process. The specifications shall include the contractor requirements for coordination, scheduling, submissions, manpower and support of the commissioning effort. The A/E shall coordinate design documents with the Commissioning Authority throughout the design period.
- B. The A/E and Contractor shall coordinate submittal documents with the Commissioning Authority throughout the construction period.
- C. THE A/E and/or Commissioning Authority shall work with the owner to develop the Operation and Maintenance requirements for installed systems and coordinate these requirements with the Contractor.

**3.2 OPERATION AND MAINTENANCE DOCUMENTATION**

- A. Operation and Maintenance Documentation shall be submitted at substantial completion. Refer to Project Close Out requirements in [Section 23 05 00 Common Work Results for HVAC](#) for. A/E shall determine timelines for draft submittal to ensure that A/E and Owner review comments are incorporated in the final documents.
- B. A/E shall use the latest edition ASHRAE Guideline as a basis for preparation of specifications for O&M Documentation.
- C. Reduced copies 11 inches by 17 inches of Record Drawings shall be included.

---

END OF SECTION 23 08 00

---

**SECTION 23 09 00 INSTRUMENTATION AND CONTROL FOR HVAC****PART 1 – GENERAL****1.1 GENERAL PROVISIONS**

- A. Provide a DDC Computerized Energy Management control system, aka Building Automation System (BAS), to facilitate the automated HVAC system operation, scheduling and environmental control.
- B. The BAS shall interface with the University's SCADA System via USF network. Contractor shall provide appropriate device license package for USF SCADA System, contact USF-FM or IT Operational Technology for more details/requirements. The BAS integration with USF SCADA System shall include dynamic real-time Graphics, and Control, fully setup and operational for remote access, monitoring, trending and scheduling, etc. A/E design documents shall also include integration of other project related Building System Equipment (i.e., Generators and ATS equipment, etc.) into the SCADA system for monitoring. A/E should provide USF-FM with a vetted list of building system points available to be integrated. Contract documents shall include a basic Network Architecture Diagram identifying the interface and gateway requirements for communicating from each Building System Equipment/BAS to the USF network (i.e., Modbus/TCP, BACnet/IP, etc.), as necessary for the project. For further details contact USF-FM/IT Operational Technology. SCADA graphics shall include a top down tiered access approach with the following guidelines.
  1. Building Site Plans (Top Tier) showing:
    - a. Outside Air Temperature (OAT).
    - b. Building power consumption (kW).
    - c. Building power source status (utility or emergency generator).
    - d. Links to other graphic screens.
    - e. Direct link to power single line screen.
  2. Floor Plans of Building (Tier Two) showing:
    - a. All Floor Plans of Building representing separate HVAC zones, outlined with simplified floor plan layout backgrounds.
    - b. Space temperatures. Indicate approximate install location of thermostat.
    - c. Major equipment status (i.e., AHU On/Off; fuel tank level, etc.).
    - d. Links to Tier Three screens and Tier One screens.
  3. Specific Equipment Graphics (Tier Three):
    - a. Generator and Fuel Tank.
    - b. ATS
    - c. Air-handler
    - d. DX Split-System Units
- C. All new facility to be connected to the owners central control center using the Ethernet network and BACnet protocol. All BACnet devices shall be interconnected on a common BACnet IP subnet. In order to avoid addressing conflicts, a specific range of BACnet Device Instances and Network Numbers shall be assigned for each building.
  1. Device Instances

A unique Device Instance for each BACnet Device shall be assigned within the following format:

    - XXXYYYY, Where:
    - XXX is the building number per the USF-FM Campus Map.
    - YYYYY is a unique number for each device within the building. First is the number of the building controller. The second is the MS/TP LAN number. The third and fourth is the controller number and these usually match the MS/TP MAC address numbers. The FM-OPS Energy Management & Controls or USF IT Operational Technology Department can assist in coordinating these numbers.
  2. Network Numbers

A unique network number for each BACnet Network utilized (i.e. Ethernet, MS/TP, PTP) shall have a number assigned within the following format:

    - XXXYY, Where:

- XXX is the building number per the USF-FM Campus Map.
  - YY is a unique number for each network within the building. The FM-OPS Energy Management & Controls or USF IT Operational Technology Department can assist in coordinating these numbers.
3. IP Network Number  
All BACnet devices shall be interconnected on a common BACnet IP subnet. All devices communicating on this network will share the same BACnet IP Network Number. This number shall be 101.
- D. Control contractor shall complete all sensing and control installations including electrical and electronic components.

## 1.2 DRAWINGS

- A. The A/E shall provide control drawings on the bid documents that show the following:
1. Sequence of operation.
  2. All sensors location on all equipment.
  3. Type of points (Analog / Digital, Input / Output).
  4. Control Valves.
  5. Control dampers.
  6. Air Monitor sizing.
- B. The A/E shall request from the contractor to submit the following items as a minimum:
1. Provide copies of all submittal data.
  2. An overall system interconnecting diagram showing all remote panels (PCs, Field Panels, and LAN devices), and power/surge protection locations and Uninterrupted Power Supply (UPS).
  3. Distributed panel locations (site and/or building plan, as appropriate to identify physical locations).
  4. Valve and damper schedules showing size, CV, close-off pressure, configuration, capacity, Manufacturer and location.
  5. Data sheets for all hardware and software control components.
  6. Thermostat/sensor locations.
  7. A description of the methodology used to keep graphics files on various PC terminals updated and consistent with one another. (Remote computer graphics vs. site computer)
  8. A detailed point-to-point diagram of circuitry of all DDC panels. Submit on a per distributed panel basis. Typical are accepted, provided all applicable units are listed and the units are identified.
  9. A list of connected data points, including connected control unit and input or output devices.
  10. A detailed Sequence of Operations.
  11. Detailed documentation on the specific field equipment to be supplied by the Controls Contractor shall be submitted and approved prior to installations; including, but not limited to, actuators, valves, temperature sensors, surge protection, and damper operators.
  12. All schemes and methods proposed to provide lightning protection for the DDC system, entering and leaving each building shall be submitted for review and approval.
  13. The Contractor shall develop project specific verification forms for all control equipment (AHU, FCU, VAV, CPU, Printer, Chiller, etc.) and submit them to the Engineer for approval prior to use. Once they are approved, the Contractor is responsible for completing the columns identified for installed information and inspection.
  14. System verification forms are to be completed by the Contractor and verified by the A/E.
  15. A verification form is to be completed for each individual component or equipment requiring verification.
  16. The Contractor shall submit completed reports immediately after tests are performed.
    - a. Record all data gathered on site on approved verification forms.
    - b. Provide the Engineer with original of each completed verification form.
    - c. Maintain a photocopy on site of data taken during starting and testing period.
    - d. Maintain one copy of all final starting, testing, balancing and adjusting reports on site up to the issue of the interim certificate for reference purposes.
  17. All final verification forms are to be submitted in word or excel format.

18. Submit to Engineer for review and approval.
  19. Make corrections and re-submit as requested by the Engineer.
  20. The Contractor shall submit brief step-by-step description of entire starting procedure to allow the Engineer to repeat starting at any time.
  21. The Contractor shall provide the required shop drawing information and verify the correct installations and operation of each item on system verification forms. This will include information such as equipment/component code, location and nameplate data.
  22. The systems verification cannot take place before all related components have been verified as correct.
  23. Prior to startup and testing of the DDC components or systems, prepare a schedule for the required testing. Review schedule with the Engineer.
  24. Provide sufficient notice (minimum seven days) prior to commencing tests.
  25. Engineer may witness all or any portion of testing and startup procedures performed by the Contractor.
  26. The Contractor shall be present for all tests.
- C. USF shall review submittals prior to the Engineer approval.

## **PART 2 – PRODUCTS**

### **2.1 MATERIALS**

- A. Subject to compliance with terms and conditions each manufacturer agreed to provide, the following manufacturers are acceptable:
1. Tampa Campus
    - a. Trane (Native BACNET System)
    - b. Alerton (Native BACNET System)
    - c. KMC (Native BACNET System)
  2. Regional campuses may specify alternate manufactures or refer to vendors listed below. Alternate vendors for the Tampa campus shall be approved by the USF-FM, FM-OPS Energy Management & Control and USF IT Operational Technology.
    - a. Sarasota Campus
      - i. Alerton (Native BACNET System)
      - ii. ALC (Native BACNET System)
    - b. St. Petersburg Campus
      - i. Trane (Native BACNET System)
      - ii. Alerton (Native BACNET System)
      - iii. KMC (Native BACNET System)
- B. COMMUNICATIONS NETWORK, PC
1. Furnish a totally native BACnet-based system, including appropriate licensing for USF SCADA System. The SCADA system, building controllers, application controllers, and input/output devices shall communicate using the protocols and network standards as defined by ANSI/ASHRAE Standard 135-2008, BACnet. In other words, workstations and controllers, including unitary controllers, shall be native BACnet devices. No gateways shall be used for communication to controllers installed under this section. Gateways may be used for communication to existing systems or to systems installed under other sections.
  2. Each Building shall have a Global Controller with an Ethernet port that supports BACnet over IP protocol and as many MS/TP networks needed to provide for zone-by-zone control of space temperature and humidity as specified.
  3. Building controllers shall include complete energy management capabilities, including scheduling building control strategies with optimum start and logging routines. Building Automation System software and firmware shall be resident in field hardware and shall not be dependent on the operator's terminal. Provide zone-by-zone direct digital logic control of space temperature, scheduling, runtime accumulation, equipment alarm reporting, and override timers for after-hours usage.
  4. Software and Hardware tools shall be provided for field engineering such as controller replacement, troubleshooting, etc. Software passwords required to program and make

future changes with field engineering tools, including graphical programming and applications will be left with the owner.

### C. AUXILLIARY CONTROL DEVICES

#### 1. AUTOMATIC CONTROL DAMPERS AND OPERATORS

- a. Automatic control dampers shall be AMCA Certified Ultra-Low leakage Class 1A @ 1" wg static pressure differential airfoil control damper. Damper blades shall be high yield aluminum airfoil construction with stainless steel linkages, corrosion resistant axles, silicone side jamb seals and EPDM blade jamb seals molded synthetic bearings, low pressure drop similar to TAMCO Series 1000SW, or equal. Dampers shall have interlocking blades and frames. Dampers shall be designed and constructed so that the blades, frames, and linkage mechanism shall present a rigid assembly with free and easy action. Bearings shall be long-life maintenance free. Where the damper blades are installed in a vertical position, a thrust type ball bearing shall be provided for the lower bearing. All bearings in ducts or casings to the outside shall have the top and bottom edges on both ends trimmed with replaceable neoprene seal fastened in an approved manner, so as to be practically air tight when closed. Dampers shall be designed for operation in temperatures ranging from -40°F (-40°C) to 212°F (100°C).
- b. The Control Contractor shall furnish all the controlled dampers of the type and sizes indicated on the Drawings for installation by the Sheet Metal subcontractor or the Mechanical contractor.
- c. All two-position control dampers shall be sized for minimum pressure drop, at the specified duct size.
- d. All modulating dampers shall be sized for an effective linear air flow control characteristic within the angle of rotation and maximum pressure drop specified. Information shall be provided to the Sheet metal subcontractor for determining the proper duct reductions or baffles used.
- e. Dampers shall be of the parallel blade design for isolation application and opposed blade design for modulating service.
- f. Approved damper operator manufacturer is: Belimo.

#### 2. AUTOMATIC CONTROL VALVES AND OPERATORS

- a. The A/E shall specify Two-Way Belimo pressure independent control valves for control of all Chilled Water and Heating Hot Water Hydronic Coil systems unless otherwise reviewed and approved by USF-FM. Chiller/Boiler Plant Control valves shall be Belimo industrial actuators for automatic butterfly valve applications.
- b. The Control Contractor shall furnish all the control valves of the type indicated on the drawings for installation by the Mechanical Contractor.
- d. All modulating straight-through water valves shall have equal percentage or linear flow characteristic.
- e. Valves 2 inches and smaller shall have brass or bronze bodies with screwed ends. Valves 2-1/2 inches and larger shall have iron bodies brass or bronze trimming with flanged ends. Valves shall be factory rated to withstand the pressures encountered. Valves shall have stainless steel stems and spring loaded Teflon packing.
- f. Air handling unit water valves shall be sized for a pressure drop equal to the coil they serve but not to exceed 5 psi. Valves shall have replaceable seats and discs. Provide pressure drop at half flow with submittals.
- g. All automatic control valves shall be fully modulating type unless specified otherwise by the project engineer.
- h. All control valves shall be designed to fail as follows:
  - i. Cooling - Fail fully open to coil.
  - j. Heating - Fail fully closed to coil.
- k. Each valve operator shall be 0-10 or 2-10 VDC type, with spring return or manual position override and feedback.
- l. Valves actuators shall be mounted vertical only.
- m. Valves and Actuators shall be Belimo.

3. **CURRENT SWITCHES:** Provide a solid state switch which indicates state change when the current level sensed by the internal current transformer exceeds the adjustable trip point. Internal circuits are to be totally powered by induction from the line being monitored. Provide a zero off-state leakage in the solid-state relay output, while switching both AC and DC circuits. Provide an LED that will show three pieces of information. (Rapid Flashing-switch is tripped, Slow Flashing-current is present but below the trip point and no Flashing-current is either off or below the bottom of the range) and permits setting the trip point adjustment prior to system connection.
4. **DIFFERENTIAL PRESSURE TRANSMITTER (DPT):** DPT shall be provided as indicated by the sequence for status purposes for either air or water applications. DPT for Building HVAC air pressure applications shall be true analog input signal with LCD display for local reading as manufactured by Dwyer Instruments or equivalent. DPT for filter status monitoring shall be Dwyer model MS-311-LCD. DPT for water applications in Building HVAC shall be true analog input signal with LCD display for local reading as manufactured by Setra, Veris or equivalent. DPT for low differential pressure with high gauge pressure applications (such as chiller evaporator differential pressure) shall be as manufactured by Mercoid, Rosemount or equivalent. Units shall be selected for ranges consistent with the application.
5. **ELECTRONIC TEMPERATURE SENSORS:**
  - a. Temperature sensors shall be thermistors or 100 Ohm platinum RTD. Sensors shall be calibrated to less than or equal to a 1/4 degrees F resolution for the specific application. Substitutions must be approved by the Engineer. All sensors to be field verified as correct.
  - b. Provide twisted pair lead wires and shield for input circuit or as otherwise required by the manufacturer.
  - c. Use insertion elements in ducts not affected by temperature stratification or smaller than one square meter. Use averaging elements where larger or prone to stratification. Sensor length 2.5 m or 5 m as required.
  - d. Insertion elements for liquids shall be one piece machined stainless steel sockets (thermo-wells) with minimum insertion length of 2-1/2 inches (60 mm).
  - e. Provide outside air sensors with watertight inlet fittings, shielded from direct rays of the sun. Mount on the North side of the facility. Outside air sensor shall be Dwyer Instruments RHP-2R22 or preapproved equivalent.
  - f. The temperature sensors shall be field verified by the Installing Contractor. Engineer will spot check verify these calibrations during walk through inspection.
  - g. Wall mounted sensor shall be mounted at 5 feet-6 inches above finished floor in an area where they are unobstructed and which free air current is not constricted or blocked, final location shall be approved by the Owner and Engineer prior to installation. Wall sensors in corridors shall have a locking guard. Use digital wall sensors. Control Contractor shall submit floor plan showing location of each device with relative equipment, door swing and relevant casework/furniture, etc. information clearly indicated.
  - h. Sensor elements shall be applicable for the medium being sensed; i.e., room elements, well mounted elements, duct mounted elements and outdoor mounted elements. Range shall be from 0 to 150 °F.
  - i. Strap on sensors shall not be used unless specifically required.
6. **ELECTRONIC STATIC PRESSURE SENSORS**
  - a. Static pressure sensors shall be differential pressure sensors, with the "high" output sensing the duct pressure and the "low" input sensing atmospheric pressure.
  - b. The range for the static pressure sensor shall be matched to the static pressure of the system being sensed, 0 to 0.5-inches, 0 to 2-inches, 0 to 5-inches, or 0 to 10-inches.
  - c. Accuracy shall be plus or minus 2 % of the full range being sensed.
7. **FIRESTATS:** Provide UL-listed fire protection thermostats where indicated in main supply and return air ducts of air handling units which are rated less than 2,000 cfm. Connect thermostats which are capable of stopping fans in event of excessive temperatures in fan control circuits. Provide thermostats with fixed or adjustable settings to operate at not less

- than 75 °F above normal maximum temperature at their location in the air handling system. Comply with requirements of NFPA 90A. Provide thermostats with the following operating features: Provide manual reset type thermostat.
8. TEMPERATURE THERMOSTATS (Stand/alone applications, as required): Two position (On/Off) room thermostat with bimetallic sensing element, set point thumb wheel dial, room temperature indicator, surface mounting base, and hard plastic cover plate, UL listed.
  9. HUMIDITY SENSOR/TRANSMITTER: Provide relative humidity sensor/transmitter where shown on the control drawings. Sensor and transmitter shall have a sensor accuracy of ±2 % RH @ 25 °C from 20-90 % RH Output Signal, two wire 0-10 VDC linear, proportional to 5-95 % RH Output Signal. The transmitter power shall be compatible with and powered by, the low voltage power supplied by this Contractor.
  10. CARBON DIOXIDE GAS SENSOR/TRANSMITTER: A/E shall not use carbon dioxide sensors except were necessary for LEED and/or for Demand Control Ventilation applications or as deemed necessary by the A/E for a specific control requirement. Provide carbon dioxide gas sensor/transmitter where shown on the control drawings. Sensor and transmitter shall have a sensor accuracy of ±5 % full scale with a typical sensing range of 0-2000 ppm. The output signal shall be 0-10 VDC linear, proportional to 0-2000ppm. The transmitter power shall be compatible with and powered by, the low voltage power supplied by this Contractor.
  11. VOLATILE ORGANIC COMPOUNDS SENSOR/TRANSMITTER: A/E shall not use VOC sensors except were necessary for LEED and/or for Demand Control Ventilation applications or as deemed necessary by the A/E for a specific control requirement. Provide VOC sensor/transmitter where shown on the control drawings. Sensor and transmitter shall have a typical sensing range that is equivalent to a CO2 level of 0-2000 ppm. The output signal shall be 0-10 VDC linear. The transmitter power shall be compatible with and powered by, the low voltage power supplied by this Contractor.
  12. AIR MONITOR AND CONTROL: Each VAV air handling unit shall have an airflow control station capable of performing constant volume control of outside air without loss of dehumidification at part load. The intent is for the controls to be an integral part of the Building Management and Automatic Temperature Control System.
    - a. Each airflow monitor and control station shall be complete with velocity pressure transmitter and air volume flow rate control.
    - b. The major control instruments shall be of industrial process control quality and shall be capable of the following minimum performance:
    - c. Differential Pressure Transducer: The differential pressure transducer shall be capable of transmitting a linear 0-10 VDC output signal proportional to the differential (velocity) pressure input signals within the following performance and applications criteria.
    - d. Calibrated Spans: not greater than 1-1/2 times the maximum design velocity pressure. Calibrated Overall Accuracy: ±1.0 % of span.
    - e. Repeatability: ±0.05 % of output.
    - f. Operating Range of Sensor: 20 °F to 150 °F
    - g. Operating Range of Transmitter: 20 °F to 150 °F
    - h. The transmitter output shall be unaffected by direction (or attitude) of mounting or external vibrations, and shall be furnished with a factory calibrated span.
    - i. Units to comply with minimum manufacturers up and downstream configuration to be coordinated with [Division 23](#) Contractor.
  13. AIRFLOW MEASURING STATIONS (DUCT AIRFLOW MEASURING DEVICE):
    - a. Each device shall be designed and built to comply with, and provide results in accordance with accepted practice as defined for system testing in the latest revision of ASHRAE Handbook of Fundamentals as well as the latest revision of the Industrial Ventilation Handbook.
    - b. Each device shall be designed and built to provide airflow readings across the entire operating airflow range, and capable of operating at 0 - 5000 fpm airflow velocities.
    - c. The maximum allowable pressure loss through the unit shall not exceed 0.1-inch wg. Each sensor node shall be calibrated to 16 points of velocity and be capable of

- measuring the airflow rate within an accuracy of  $\pm 2\%$  of reading,  $\pm 0.25\%$  repeatability. Each Air Flow Measurement System shall be capable of measuring the airflow rate at an installed location which meets Manufacturer's Suggested Placement Guidelines to within  $\pm 3\%$  of Reading at any velocity between 0 to 5,000 feet per minute.
- d. Stations shall be installed in strict accordance with the manufacturer's published requirements. Modulating control dampers shall be installed downstream of air monitoring stations. Placement of air monitor stations in duct shall be coordinated by the installing Contractor with the manufacturer's local representative prior to installation based on the project actual field conditions. These stations serve as the primary signals for the airflow control systems; therefore it shall be the responsibility of the Contractor to verify location and installation to assure that accurate primary signals are obtained.
  - e. The units shall have a self-generated sound rating of less than NC40, and the sound level within the duct shall not be amplified nor shall additional sound be generated.
  - f. A/E shall specify similar to Ebtron Advantage III Gold Series Thermal Dispersion Technology or pre-approved substitute. All airflow measuring stations shall comply with the above technical requirements. In the event of noncompliance with the above technical and performance requirements the installing Contractor shall be responsible for providing replacement airflow measurement systems which do meet the requirements.
  - g. Airflow measuring stations shall be scheduled on the drawings and shown on floor plan/ductwork drawings. Drawing shall show access doors (required for cleaning) and all necessary upstream and downstream clearances.
  - h. Each air monitor shall be tested by the project test & balance contractor. Tests shall be conducted at each air-handlers minimum and maximum operating fan capacity. If the installed air flow measurement systems readings and project test & balance measurement values deviate more than allowable project specification, adjustments are to be made in conformance with Manufacturers delineated adjustment procedures.
14. WATER FLOW METER
- a. For Water Flow Meter requirements, refer to [Section 23 05 19 Meters and Gages for HVAC Piping](#).
15. BTU METERING
- a. For BTU Meter requirements, refer to [Section 23 05 19 Meters and Gages for HVAC Piping](#).
16. REFRIGERATION LEAK DETECTORS:
- a. Provide refrigerant leak detectors with up to four (4) remote sensor inputs, controller furnished complete with alarm relays and control relays for Start - Stop control of area makeup and exhaust fans. Sensors will be solid state to include Ammonia and Freon. R-22, R-123 and 134 shall be provided to match selected chiller. Sensors can be located up to 500 feet from the control unit. Control unit to include visual alarms with discreet LED's for which sensor has caused the alarm. System will have a built in time delay to prevent false alarms. Provide panel with test buttons for audible and visual alarms.
  - b. Acceptable Manufacturers - MSA Instruments.
17. LOW TEMPERATURE LIMIT SENSORS (Coil Freeze Protection): Provide low temperature protection thermostats of manual-reset type, with sensing elements 8 feet or 20 feet in length. Provide thermostat designed to operate in response to coldest 1 foot length of sensing element, regardless of temperature at other parts of element. Support element properly to cover entire duct width. Provide separate thermostats for each 25 square feet of coil face area or fraction thereof.
18. CONTROL WIRING: All conductors shall be of stranded copper wire.
- a. All PVC/EMT/rigid steel conduit and outlet boxes shall conform to the requirements specified under [Division 26, Electrical](#).
  - b. All cable runs exposed in return air plenums shall be smoke rated for the application and secured to the building structure. Do not run wire in drywall without conduit.
  - c. All wiring cables shall have 600 volt insulation.



- d. Cables shall be properly identified/tagged with matching wire markers on both ends as to the control point.
- e. All cables from ceilings to wall temperature sensors shall be installed in conduit (EMT). EMT Conduit fittings shall be steel compression type. Set Screw fittings are not acceptable.
- f. Non conduit wires (exposed wires above ceiling) will be decided by the detail spec (project scope).

**PART 3 -- EXECUTION (Not Used)**

---

END OF SECTION 23 09 00

---

**SECTION 23 21 13 HYDRONIC PIPING****PART 1 – GENERAL****1.1 PERFORMANCE REQUIREMENTS**

- A. Design piping systems in accordance with the requirements set forth and no less than the minimum per the latest Florida Mechanical Code requirements.
- B. Pipe wall thickness. Wall thickness shall be calculated as per ASME B31.3.
- C. A material allowance shall be added to the above calculated wall thickness to account for progressive deterioration due to the effect of corrosion, erosion, wear, and material removed for threading or grooving.
- D. Design temperatures shall be 45 °F for chilled water, 160 °F for hot water, and 95 °F for condenser water. Design pressures for distribution shall be 200 psi. Refer to Section 23 00 00 1.2 Design Criteria for additional requirements.
- E. Condenser water design pressures shall be determined by the A/E.

**PART 2 – PRODUCTS****2.1 MATERIALS**

- A. Above ground PIPES & PIPE FITTINGS
  1. General: No PVC pipe shall be used.
  2. Steel Pipe: Steel pipe shall be ASTM A53 Seamless pipe (Type-S) Grade B. If other standard needs to be specified, Engineer shall discuss with Owner.
  3. Steel fittings shall be ASTM A234 wp 91 tempered.
  4. Piping 2 inches and smaller may be Type K copper tubing with 95-5 sweated fittings. Mechanical pressed copper pipe jointing piping similar to Viiega Pro Press System or approved equal may be used inside buildings for chilled water and heating hot water piping 2 inches and smaller upon written substitution request and approval by the USF-FM. Approvals will be contingent on base building system materials, cost considerations, installation time and use of space. All of the piping system components in project mechanical joining piping systems shall be of single manufacturer including joints, pipe, installation tools, couplings, gaskets, fittings, valves and accessories, etc. A direct employee of the jointing system manufacturer shall provide on-site contractor training and installation inspection by the manufacturers authorized representative. The manufacturer's Installation Services representative shall inspect project for properly-installed pipe joints and complete system integrity. Upon completion of each inspection, the manufacturer's Installation Services representative shall provide a report to USF, Contractor and the Engineer to identify any deficiencies and/or contractor action items. Mechanical joining piping system manufacturers shall provide owner training and provide any/all installation tools needed for maintaining the system. Owner training shall be provided for up to 4 hours of hands on maintenance and repair training for four FM-OPS personnel as scheduled via USF-PM at time of Substantial Completion. Mechanical joining piping system manufacturers shall provide USF with long-term Extended Warranty on each project-accepted for installation.
  5. Condensate Drain Piping -Type K or L copper tubing with 95-5 sweated fittings.
- B. UNDERGROUND PRE-INSULATED PIPES
  1. Underground pipes shall be factory pre-insulated steel piping.
  2. The carrier pipe shall be steel ASTM A-53, Grade B, seamless (Type S), standard weight for sizes 2 inches and larger, and shall be ASTM A-120/A-53, Grade F (Type F), standard weight for sizes 1 to 1 1/2-inches and smaller. Seamless pipe smaller than 2 inches shall be ASTM A-106, or A53, Grade B. Condensate return piping shall be Schedule 80. When practical, piping shall be provided in 40 feet double-random lengths. All carbon steel pipe shall have ends cut square and beveled for butt welding. Straight sections of factory insulated pipe shall be 6 inches of exposed pipe at each end for field joint fabrication.
  3. Polyurethane foam insulation shall be injected with one shot into the annular space between carrier pipe and jacket with a minimum insulation thickness of 3 inches. Insulation shall be rigid, 90-95 % closed cell polyurethane with a 2.0-to-3.0 pounds per cubic foot density and coefficient of thermal conductivity (K-Factor) of 0.14 and shall conform to ASTM C-591. Maximum operating temperatures shall not exceed 250 °F. Insulation thickness shall be specified by calling out appropriate carrier pipe and jacket size combinations.

4. Jacketing material shall be high density polyethylene (HDPE), conforming to ASTM D-1248. Wall thickness for HDPE jacketing shall vary according to pipe size. Piping wrap shall be heat shrunk at closures. Jacketing for above ground, outdoors installations shall contain ultraviolet inhibitors for protection for sunlight. No FRP jacket allowed.

### **PART 3 – EXECUTION**

#### **3.1 EXECUTION**

- A. All piping, fittings, specialties, etc. are to be installed in strict accordance with manufacturer's instructions and sound engineering and Code practices.
- B. Pipe 2 inches and smaller shall be threaded or socket welded.
- C. Pipe greater than 2 inches shall be three-pass butt welded. Root pass shall be inspected before other passes are made.
- D. Piping installation is to be level. Pipe is to be concealed in chases except in unfinished rooms and when installed above ceiling. No PVC pipe is to be used. Flexible connections are to be installed at all vibrating equipment. Pipe branches from mains must incorporate one change of direction in horizontal plane and one in vertical plane before connecting to equipment. Change of direction are not required if main piping is anchored at branch take-off. Drain valves are to be installed at low points in piping to permit draining of system. Di-electric unions are to be provided between dissimilar metals. Each piece of equipment is to be provided with shut off isolation valves. Air vents are to be installed at all high points, piping drops, and other points where necessary for air removal. A back flow preventer and shut off is to be provided at water service connection.
- E. Balancing valves and orifices are to be provided sufficient lengths of straight pipe upstream and downstream of valves, fittings, etc. to reduce turbulence to a minimum.
- F. Condensate piping is to be pitched a minimum of 1/8 inch per foot and provided with clean-outs at every 90 bend and at convenient intervals in straight lines. A trap is to be provided at each equipment connection to drain. Water seal must exceed maximum pressure developed by equipment.
- G. Buried piping is to be at a minimum of 48 inches for Tampa campus, and 36 inches for Sarasota and St. Petersburg campuses. Joints and fittings are to be carefully excavated and buried so that the piping load is not supported by the joint, etc.
- H. Sleeves are to provide at least 1 inch clearance all around pipe and insulation and are to be sealed in exposed areas, through fire walls with fire proofed sealant, and partitions. Insulation must be continuous through sleeves. Where pipes pass through floors top of sleeve is to be set 2 inches above finished floor and flush with underside of floor. Unused sleeves are to be plugged.
- I. Hydronic Testing – Piping System are to be purged of all air and hydrostatically tested at 1.5 times the maximum system design pressure, but not less than 100 psig for a minimum of 15 minutes. No pressure drop is to be allowed. The A/E and Owner's representative are to witness the tests. Any leaks are to be repaired by replacing defective fitting, joint or piece. Defective section is to be re-tested after repair and witnessed by the Project Architect/Engineer and the Owner's representative. Back filling, concealing, and insulating is to be done after successful hydrostatic test and after Inspector approval.
- J. Adjusting and Cleaning - Clean and flush hydronic piping system.
- K. Piping Supports - All piping supported from the ceiling shall have at least one foot long saddles of sufficient strength to ensure pipe hangers do not cut into the insulation.
- L. Provide P/T Plugs on branch piping at equipment entering and leaving connections. Locations shall allow field measurement of fluid temperatures and pressures across individual equipment for verification and troubleshooting.
- M. All chilled water piping (includes piping to be reused as part of renovation or refurbishment project) shall be prepared and painted with 2 coats of an epoxy paint after pressure testing is complete and prior to installing insulation. Do not install insulation on wet piping.

---

END OF SECTION 23 31 13

---

**SECTION 23 31 13 HVAC DUCTWORK****PART 1 – GENERAL****1.1 GENERAL PROVISIONS****A. DRAWINGS**

1. Contract drawings shall identify the portion of each duct system to be constructed for a particular pressure class.
2. Contract drawings shall identify and designate the duct pressure class for each system. All ducts shall be constructed in accordance with SMACNA and meet or exceed the specific duct pressure class for each system. All ducts shall be sealed to Seal Class A for duct closure. A/E shall specify the sealant to be used.
3. Contract drawings shall indicate all service openings as required by NFPA. Special attention should be given to access coils for cleaning.
4. Contract drawings shall indicate all openings for thermometers and controllers.
5. Contract drawings shall indicate all dampers, all necessary details, hanger/supports details, and spacing.
6. Drawings shall be double line.
7. In renovation work, contract drawings shall directly state that abandoned and/or replaced ductwork located in the HVAC scope of the project shall be removed from the building. Ambiguous areas shall be discussed with the USF-PM.

**B. SHOP DRAWINGS**

1. A/E shall specify shop drawings to be submitted for A/E approval before fabricating ductwork. Two (2) approved copies shall be sent to owner.
2. Shop drawings shall include as a minimum:
3. Mark of each duct section
4. Pressure class of the duct section
5. Gauge of material
6. Duct reinforcement (if any)
7. Transverse joint reinforcement
8. Longitudinal seam
9. Intermediate reinforcement (if any)
10. Hanger type, size and spacing. Anchor method and lower hanger detail.

**1.2 DESIGN CRITERIA**

- A. A/E shall select the duct sizing method and report same to the owner. Special attention should be given to noise control when selecting sizing method and materials.
- B. Return air system shall be ducted directly back to the air handling unit. Return air plenums shall not be used unless as a last resort, and the engineer has evaluated and proven to the USF Mechanical Engineer that return ducting is not possible; as dictated by existing building structural or physical constraints. Comply with the current FBC building envelope insulation requirements where return plenums are to be used or reused.
- C. Internal duct liner SHALL NOT be specified, unless discussed with Owner.
- D. Fibrous duct SHALL NOT be specified.
- E. Generally duct material shall be galvanized (G90) steel except as noted. A/E shall analyze each environment and make recommendations on 1). the galvanized coating designation or 2). the selection of alternative duct materials e.g. fiberglass, PVC, Stainless steel etc.
- F. Fume Hood exhaust duct shall be welded stainless steel except as recommended otherwise by A/E for the specific fluid handling application or installation circumstances.
- G. Kitchen and Dishwasher Hood exhaust duct shall be welded stainless steel.
- F. Maximum developed length of flexible duct shall be 6 feet.
- G. Specify double wall turning vanes for ducts supply and return.

**PART 2 – PRODUCTS****2.1 MATERIALS**

- A. Sheet metal shall be per ASTM A-653 regular spangled, non-oiled with a minimum zinc coating designation of G90. A/E shall make recommendations.

- B. Threaded rod hangers, when used, shall be galvanized with double nuts and lock washers.
- C. Take-off fitting with damper: Shall be commercial quality with continuous weld seams, heavy duty damper & handle with standoff to allow blanket type insulation, conical similar to FlexMaster USA model STOD-B03 with full width damper rod with nylon bushings or equal bellmouth or rectangular to round shoe take-offs.
- D. Outside Air and Return Air Control Dampers: Refer to [Section 23 09 00 Instrumentation and Control for HVAC. Subparagraph C, Auxiliary Control Devices, 1. Automatic Control Dampers and Operators](#)

### **PART 3 – EXECUTION**

#### **3.1 EXECUTION**

- A. Generally ducts shall be installed 4 inches below the building structure above.
- B. Leakage testing must be specified, per SMACNA criteria. The A/E should specify that the testing is witnessed by the Engineer, TBA agency, and the owner representative.
- C. All ducts openings shall be protected with visqueen during construction. If ducts were not protected, then the Contractor shall vacuum before starting of air handler fans, at no cost to the Owner.
- D. Welding shall be as per specification for welding sheet metal (AWS 1990).
- E. Ducts shall have access doors every 50 feet.

---

END OF SECTION 23 31 13

---

**SECTION 23 34 23 HVAC POWER VENTILATORS****PART 1 – GENERAL****1.1 PERFORMANCE REQUIREMENT**

- A. Fans shall be direct drives with speed controllers. If fan duty cannot be achieved, the A/E shall discuss potential options with USF before selection is made.
- B. Fan noise levels shall be selected to achieve the NC levels in all occupied spaces (at lower end of the range) as per the latest edition of ASHRAE HVAC Application Handbook.
- C. Fan operation shall be verified (thru BAS) by flow switch for belt drives and flow switch/current sensor for direct drive.
- D. Don't use axial flow fans unless written permission is granted

**PART 2 – PRODUCTS****2.1 MATERIALS**

- A. Engineer shall analyze the environments (both inside and outside), select materials to ensure long life with minimum maintenance, and discuss the selections before schematic submittals.

**PART 3 – EXECUTION****3.1 EXECUTION**

- A. Provide fixed sheaves after final balance.

---

END OF SECTION 23 34 23

---

**SECTION 23 37 13 DIFFUSERS, REGISTERS AND GRILLS****PART 1 – GENERAL****1.1 DESIGN CRITERIA**

- A. A/E shall select and schedule air devices for the specific application on a room by room basis to achieve the mixing ventilation and distributed airflow necessary for desired comfort of the space.
  - 1. Indicate materials of construction, finish, and mounting details; and performance data including throw and drop, static-pressure drop, and noise ratings.
  - 2. Indicate drawing designation, room location, quantity, model number, size, and accessories furnished.
- B. Air devices shall be selected based on best industry practices necessary to achieve quiet operation throughout the operating range of the device. Refer to the specific noise criteria limits for the given application/space.
- C. Submit engineering data in a manner to facilitate convenient review of aspiration ability, including temperature and velocity traverses, throw and drop, noise criteria ratings sizes, free area and quality of construction. Outlets shall be selected for maximum noise criteria level as scheduled on drawings.
- D. Verification of Performance: Rate diffusers, registers, and grilles according to ASHRAE 70, "Method of Testing for Rating the Performance of Air Outlets and Inlets."

**PART 2 – PRODUCTS****2.1 MATERIALS**

- A. Indoor air devices shall be constructed of Aluminum unless the application dictates otherwise (i.e.; highly corrosive environments).
- B. Finish shall be powder coat or baked enamel, white unless otherwise required for the application.

**PART 3 – EXECUTION****3.1 EXECUTION**

- A. Install diffusers, registers, and grilles level and plumb.
- B. Ceiling-Mounted Outlets and Inlets: Drawings indicate general arrangement of ducts, fittings, and accessories. Air outlet and inlet locations have been indicated to achieve design requirements for air volume, noise criteria, airflow pattern, throw, and pressure drop. Make final locations where indicated, as much as practical. For units installed in lay-in ceiling panels, locate units in the center of panel. Where architectural features or other items conflict with installation, notify Architect for a determination of final location.
- C. Install diffusers, registers, and grilles with airtight connections to ducts and to allow service and maintenance of dampers, air extractors, and fire dampers.
- D. Provide accessible balancing dampers in duct branches and/or devices were necessary to allow for proper balancing. Dampers shall be selected and installed so as not to induce air noise above the noise criteria of the room.
- E. Paint ductwork visible behind air outlets and inlets matte black.
- F. After installation, adjust diffusers, registers, and grilles to air patterns indicated, or as directed, before starting air balancing.

---

END OF SECTION 23 37 13

---

**SECTION 23 41 00 PARTICULATE AIR FILTRATION****PART 1 – GENERAL****1.1 DESIGN CRITERIA**

- A. Drawing shall indicate filter removal/replacement space which shall be dimensioned. Air handler schedule shall include filter size.
- B. Filter efficiencies shall be selected based on the areas served. Engineer shall address special filtration needs at advanced schematic.

**PART 2 – PRODUCTS****2.1 MATERIALS**

- A. Provide 2 inches thick pre-filters, with MERV 8 minimum efficiency. Pre-filters shall be Pleated type.
- B. Provide 4 inches thick final-filters, with MERV 13 minimum efficiency. Final Filters shall be Cartridge type. No roll filters.

**PART 3 – EXECUTION****3.1 EXECUTION**

- A. During construction filter pressure drop shall be monitored. Filters shall be replaced when pressure drop reads the manufacturers recommended loaded filter pressure drop (approximately 1 inch of water column).
- B. New filters shall be installed at substantial completion.
- C. Three (3) spare sets of main filters shall be supplied to USF at substantial completion.

---

END OF SECTION 23 41 00



---

**SECTION 23 73 13 MODULAR INDOOR CENTRAL STATION AIR HANDLING UNITS****PART 1 – GENERAL****1.1 PERFORMANCE REQUIREMENT**

- A. Engineer shall discuss type of Air Handler (draw through, blow through, etc.) with USF before selection is made. Energy efficiency shall be of paramount concern. Typical design shall be VAV system with no simultaneous heating and cooling.
- B. Roof mounted air-handlers are not allowed unless an exception is requested and approved by USF-FM.
- C. Do not use axial flow fans unless written permission is granted.
- D. Access doors shall be provided for service of all components.
- E. For special applications, Engineer shall discuss recommendations with USF at Advanced Schematic.
- F. Air-handler cooling coils selections shall be based on a nominal leaving air temperature of 52 °F and 15 °F water temperature rise. Hot water coils shall be based on a 50 °F water temperature drop. (Note: This difference shall be measured at the mains. (Engineer shall show calculations for mixed flow to verify the temperature in the pipe mains.)
- G. Three-way mixing or bypass valves are not acceptable. Use only two-way pressure independent control valves. Refer to [Section 23 09 00, Instrumentation And Control For HVAC, 2. Automatic Control Valves and Operators](#) for additional requirements.
- H. Each AHU shall have temperature and pressure plugs (P/T) on the supply and return chilled and hot water lines.
- I. All 100% outside air units shall be equipped with preheat coils.
- J. Provide Energy Recovery Ventilation Systems in accordance with the Florida Building Code – Energy Conservation (latest Edition). Wrap around Heat Pipes may be used in air-handler applications for code required Energy Recovery Devices where specific code exceptions allow its use. Heat Pipes shall be installed at the air-handler factory. Systems shall include nominally 12 inches of upstream and downstream coil clearances for maintenance and instrumentation. All wraparound heat pipes shall include full controllability (all circuits) and shall be controlled by the BAS sequence of operations and be capable of being fully isolated (turned-off) via heat pipe control valve(s). When heat pipe is isolated by control valve, there shall be no residual heat output from the heat pipe coil. If the manufactured heat pipe contributes any residual heat to system supply air temperature, this heat output shall be accounted for in the A/E design (i.e., increasing the system design airflow, cooling coil capacity, etc.) in order to satisfy the cooling space peak sensible load.
- K. Energy Recovery Systems may be used on air-handler applications other than where dictated by code if it is suitable for the application and deemed feasible. The Project Engineer shall provide a Life Cycle Cost Analysis (LCCA) for all air-handler projects (new and/or replacements) on all non-code required applications. The LCCA shall be performed by the Project Engineer of Record (Florida Professional Engineer) and submitted to the USF Mechanical Engineer for review. The LCCA shall include a simple payback method based on modeled calculations of annual energy savings and include the net installed first cost for the energy recovery system and the annual maintenance costs. Modeled energy savings may be calculated using an approved hourly load model or an approved BIN load model specific to the project location, weather data and operating schedule. The energy savings model shall adjust for fan energy costs (additional system static pressure work and airflow), and heat transfer effectiveness of the proposed equipment, etc. The energy calculations shall be performed using the most recent utility costs as determined by USF FM. Systems resulting in favorable payback will be given consideration for inclusion as determined by USF Leadership. The first cost pricing shall contain control system costs to include instrumentation (i.e.; temperature/humidity sensors) located upstream and downstream of the heat exchanger coils for monitoring and trending real time performance data. The system net first cost value shall include the cost to increase unit size/airflow as needed to achieve design capacity and the cost to enlarge mechanical rooms as needed for proper clearances. Annual maintenance costs may be estimated at \$700 per year per system. If wraparound energy recovery systems are employed, the energy recovery system shall be fully controllable. If the reheat is designed to

- be energized during design peak conditions, the air-handler system shall be sized to compensate for any additional airflow required to satisfy the sensible design load conditions.
- L. The A/E may specify GPS IBAR for surface treatment of cooling coils in lieu of UV-C Lamps provided the air-handler control system includes VOC and CO<sub>2</sub> sensors installed in the return airstream for monitoring and trending room air quality and the IBAR power supply is mounted outside of the unit for maintenance access and visual feedback to determine operating status. The power to the IBAR shall be interlocked with the air-handler and shut-off anytime the air-handler is off.
  - M. Fan walls shall be given consideration for use on air-handlers. Review job specific details and options with the USF-PM and USF Mechanical Engineer at the Schematic Phase level before finalizing air-handler selections.
  - N. Acceptable Air Handler manufacturers: Trane, York and Carrier.

## PART 2 – PRODUCTS

### 2.1 MATERIALS

- A. Air handling unit shall be insulated double walled with no exposed insulation in the air stream.
- B. Drain pan shall be extended length stainless steel positively sloping IAQ type drain pans.
- C. The preferred maximum number of hydronic cooling coil row/fins per inch (fpi) is 6/14. If coil duty requires greater row/fpi then unit shall be equipped with UV-C lamps and adequate clearances for cleaning and maintenance. If required to exceed 6 rows, consider split coils provided with access clearance between coils for cleaning.
- D. Air handler coils shall be specified with stainless steel frame, stainless steel bulkheads and stainless steel coil supports. A/E shall specify air-handler materials as applicable to the unit's operating environment (i.e.; for coastal environments should be specified with: stainless steel interior liner, SS coil casing/bulkheads/coil supports, Heresite P-413C using 5 step process (dry film coverage to be 2-3 mils) or equal coil and casing coating, exterior unit primed and painted with acrylic polyurethane finish) to help resist unit deterioration and extend the useful life of the equipment.
- E. Fans shall be direct drives with speed controllers. If fan duty cannot be achieved, the A/E shall discuss potential options with USF before selection is made.
  - 1. Fan noise levels shall be selected to achieve the NC levels in all occupied spaces (at lower end of the range) as per the latest edition of ASHRAE HVAC Application Handbook.
  - 2. Fan operation shall be verified (thru BAS) by flow switch for belt drives and flow switch/current sensor for direct drive.
- F. Provide Variable Frequency Drives (VFD) for all air-handler (variable air volume and constant volume) applications. Other control methods shall be approved, in writing, by USF. Each VFD to be provided with lightning surge protection and manual bypass.
- G. The VFD shall be compatible to the Energy Management System. The VFD shall accept 4-20 ma or 0-10 Volt signal to control the frequency on the drive. Furthermore, the VFD shall communicate to the BAS through BACNET protocol. Approved manufacturers are:
  - 1. ABB, Danfoss-Graham, Yaskawa, and Square D.
  - 2. Regional campus facilities may specify alternate manufacturers.

## PART 3 – EXECUTION

### 3.1 EXECUTION

- A. Air handlers shall be installed to limit noise and vibration. Provide Air-handlers Schedule. Air handlers to be floor mounted shall be installed on nominal 6" high concrete housekeeping pads. Additionally, provide double deflection neoprene pads between the concrete pad and air handler units for isolation of the dissimilar materials.
- B. With unit running, water flow test shall be done to ensure adequate condensate drainage.
- C. A limit water switch shall be installed on drain pan. Limit switch shall disable AHU.
- D. Provide ball valve and piping on air handler coil air vents.
- E. Air cleaning and filtration efficiencies for each air handling system. These shall be clearly shown on design drawings. Refer to Section 23 41 00 Particulate Air Filtration for additional requirements.

---

END OF SECTION 23 73 13